



Board of Adjustment Staff Report

Meeting Date: July 11, 2018

Agenda Item: 8B

SPECIAL USE PERMIT CASE NUMBER: WSUP18-0011 Murray Grading

BRIEF SUMMARY OF REQUEST: Grading of an area of approximately 80,000 square feet to facilitate the development of an Agricultural Sales Use Type.

STAFF PLANNER: Planner's Name: Roger Pelham, MPA, Senior Planner
Phone Number: 775.328.3622
E-mail: rpelham@washoecounty.us

CASE DESCRIPTION: For possible action, hearing, and discussion to approve Major Grading of an area of approximately 80,000 square feet on a parcel of land approximately 2.53 acres in size to facilitate the development of an Agricultural Sales Use Type.

Applicant: Murray Ranch, LLC
Property Owner: Reeves Business Ventures
Location: 225 US Highway 395 South, approximately 700 feet south of its intersection with Old Washoe Drive
APN: 046-080-03
Parcel Size: ± 2.53 Acres
Master Plan: Commercial (C)
Regulatory Zone: General Commercial (GC)
Area Plan: South Valleys
Citizen Advisory Board: South Truckee Meadows / Washoe Valley
Development Code: Authorized in Article 438, Grading
Commission District: 2 – Commissioner Lucey

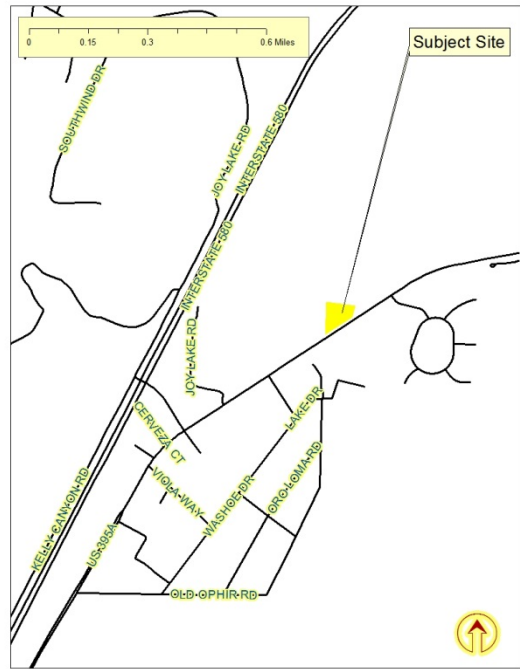

STAFF RECOMMENDATION

APPROVE

APPROVE WITH CONDITIONS

DENY

POSSIBLE MOTION

I move that, after giving reasoned consideration to the information contained in the staff report and information received during the public hearing, the Washoe County Board of Adjustment approve with conditions Special Use Permit Case Number WSUP18-0011 for Murray Ranch, LLC, having made all five findings in accordance with Washoe County Code Section 110.810.30

(Motion with Findings on Page 11)

Staff Report Contents

Special Use Permit.....3

Vicinity Map.....4

Site Plan.....5

Project Evaluation6

South Truckee Meadows/Washoe Valley Citizen Advisory Board (STM / WV CAB) 10

Reviewing Agencies10

Recommendation11

Motion11

Appeal Process12

Exhibits Contents

Conditions of ApprovalExhibit A

Agency CommentsExhibit B

Public NoticeExhibit C

Project Application.....Exhibit D

Special Use Permit

The purpose of a Special Use Permit is to allow a method of review to identify any potential harmful impacts on adjacent properties or surrounding areas for uses that may be appropriate within a regulatory zone; and to provide for a procedure whereby such uses might be permitted by further restricting or conditioning them so as to mitigate or eliminate possible adverse impacts. If the Board of Adjustment grants an approval of the Special Use Permit, that approval is subject to Conditions of Approval. Conditions of Approval are requirements that need to be completed during different stages of the proposed project. Those stages are typically:

- Prior to permit issuance (i.e. a grading permit, a building permit, etc.)
- Prior to obtaining a final inspection and/or a certificate of occupancy on a structure
- Prior to the issuance of a business license or other permits/licenses
- Some Conditions of Approval are referred to as “Operational Conditions.” These conditions must be continually complied with for the life of the business or project.

The Conditions of Approval for Special Use Permit Case Number WSUP18-0011 are attached to this staff report and will be included with the Action Order.

The subject property is designated as General Commercial (GC). The proposed Major Grading to facilitate development of an Agricultural Sales Use is permitted in the GC with a special use permit per WCC 110.438.35. Therefore, the applicant is seeking approval of this SUP from the Board of Adjustment.



Vicinity Map

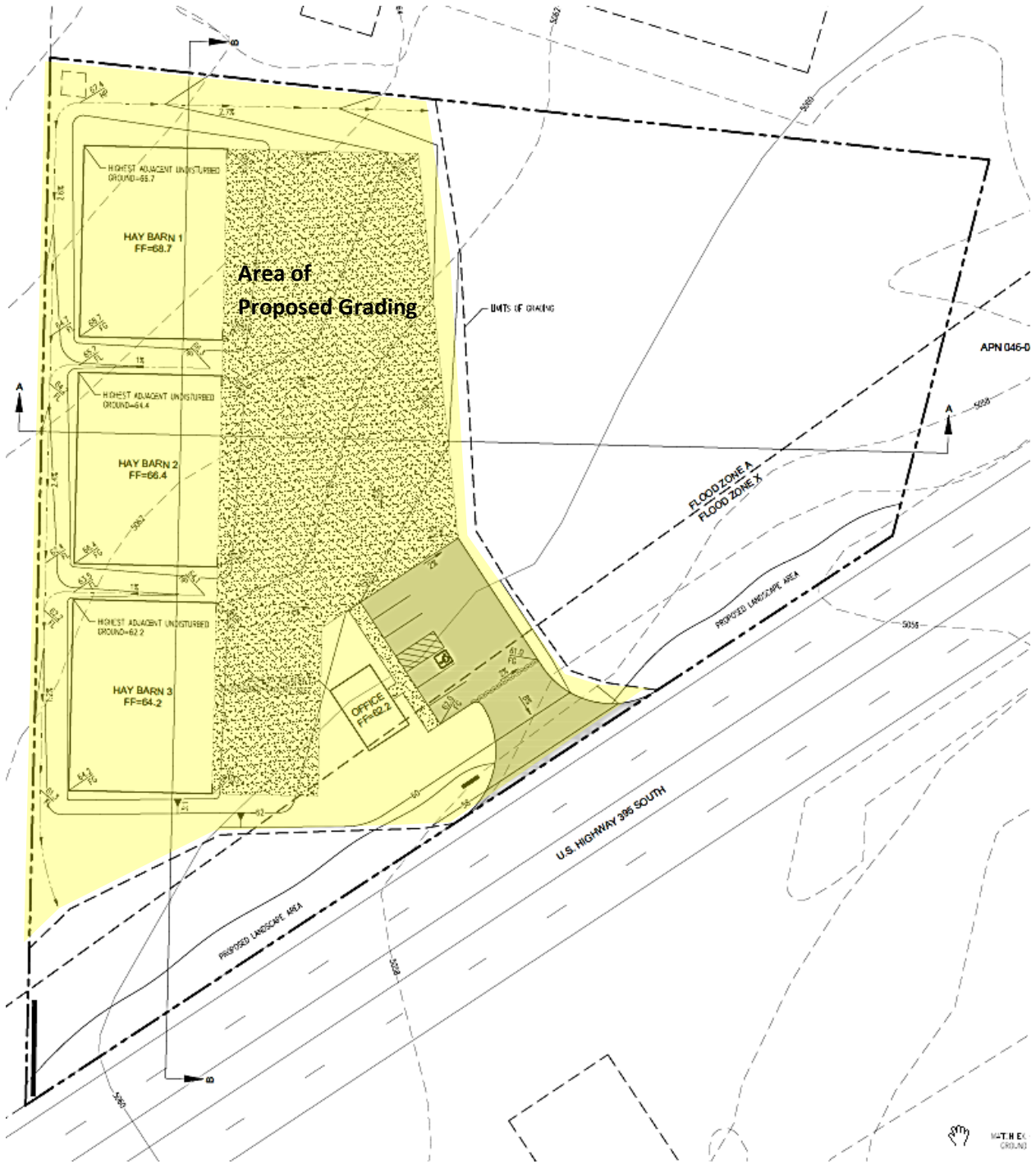

Site Plan

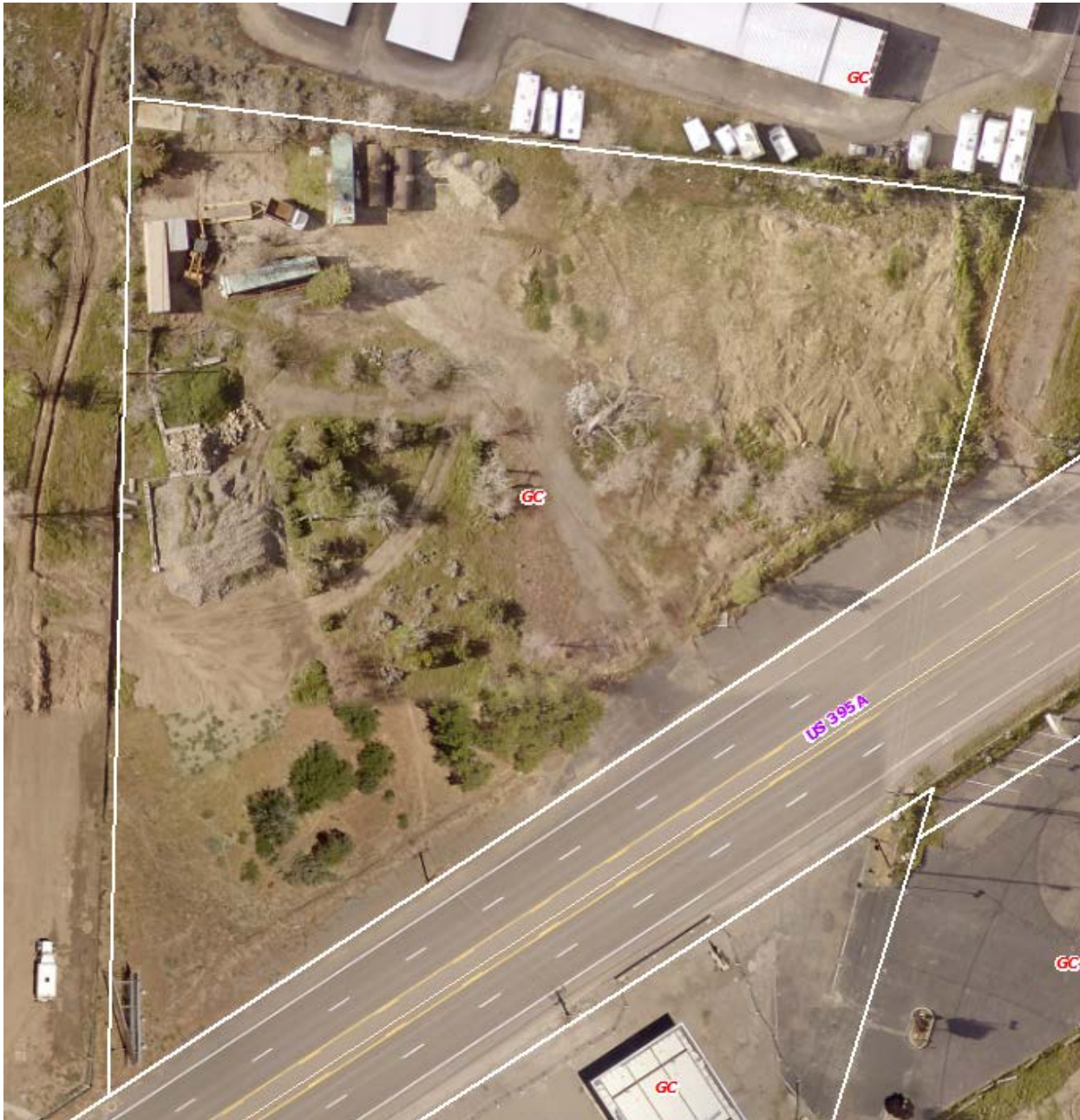

Overhead Photo of Subject Site

Project Evaluation

The plans that are being evaluated as part of this Special Use Permit request are generally in compliance with the requirements of the Article 438. The elevation of the site is proposed to be raised for creating foundations and maneuvering areas.

The subject site shows substantial evidence of previous disturbance. There are vehicles, equipment, cargo containers, and various other items on the site. As a condition of approval all such items will be removed. There are a number of areas where refuse has been dumped. A proposed condition of approval has been included to require the removal of all refuse within the limits of the project site.

There are also a significant amount of trees and vegetation on the site. Photos of the subject site follow.







There are a number of aspects of the proposed grading that are important to emphasize. Among the more significant of these is that approximately 5000 cubic yards of earthen material is proposed to be imported to elevate the foundation of the proposed hay barns. The barns are proposed to be located on the portion of the subject site containing many large trees. Conditions of approval have been included to require the applicant to submit a tree preservation plan to maintain at least half of the existing mature trees on the subject site. This may result in reconfiguration of the location of the proposed hay barns. Significant mature vegetation also exists within the subject site, adjacent to US Highway 395 South. This area is proposed to be landscaped. Conditions of approval have been included to preserve established bushes and trees to the greatest extent possible.

The proposed site is adjacent to commercial uses on both sides. Because of this, minimal buffering is necessary. Concentration of required landscaping along the highway frontage will provide a benefit to those traveling along the highway. The applicant has proposed and conditions of approval have been included to require the subject site to be surrounded by a solid fence. This will help to visually obscure the graded area.

A proposed condition of approval has been included to require revegetation of all areas disturbed by grading activities, not utilized by the proposed commercial use. That condition includes the provision that tree seeds of the type common to the subject site will be included in the revegetation seed mix. Over time, native trees may help to further mitigate the visual impact of graded areas.

Because the developed area of the subject site comprises only about half of the overall subject site, to inhibit vehicles damaging the areas that are proposed to be revegetated and to remain undisturbed, boulders and bollards are required surrounding the truck maneuvering area.

It is the evaluation of staff that the proposed grading is consistent with the Master Plan and the South Valleys Area Plan as there are no specific policies or action programs included in the South Valleys Area Plan that are applicable to the proposed grading. Further, adequate roadways and utilities are present and/or available for the site and the site is suitable for the development proposed. Likewise, given careful consideration and meaningful conditions of approval, it is the opinion of staff that approval of the proposed special use permit will not be significantly detrimental to the public health, safety or welfare; injurious to the property or improvements of adjacent properties; or detrimental to the character of the surrounding area. There is no military installation within the required notice area for this special use permit. Given this evaluation staff recommends

approval of the Special Use Permit, subject to the imposition of the proposed conditions of approval included at Exhibit A to this report.

South Truckee Meadows / Washoe Valley Citizen Advisory Board (STM / WV CAB)

The proposed project was presented by the applicant's representative at the regularly scheduled Citizen Advisory Board meeting on June 14, 2018. The attached CAB recommended approval with little discussion. **Reviewing Agencies**

The following agencies received a copy of the project application for review and evaluation.

- Washoe County Community Services Department
 - Planning and Building Division
 - Engineering and Capital Projects Division
 - Utilities/Water Rights
- Washoe County Health District
 - Air Quality Management Division
 - Vector-Borne Diseases Program
 - Environmental Health Services Division
- Washoe County Regional Animal Services
- Truckee Meadows Fire Protection District
- Regional Transportation Commission
- Washoe – Storey Conservation District

Eight out of the ten above listed agencies/departments provided comments and/or recommended conditions of approval in response to their evaluation of the project application. A summary of each agency's comments and/or recommended conditions of approval and their contact information is provided. The Conditions of Approval document is attached to this staff report and will be included with the Action Order, if approval is granted by the Board of Adjustment.

Washoe County Planning and Building Division addressed tree preservation, set landscaping, and parking standards.

Contact: Roger Pelham, 775.328.3622, rpelham@washoecounty.us

Regional Transportation Commission recommended that access be limited to "right-in and right-out" only and that bicycle/pedestrian facilities be included adjacent to US Highway 395 South. Conditions of approval have been included to require compliance with those recommendations.

Contact: Rebecca Kapuler, 775.332.0174, rkapuler@rtcwashoe.com

Staff Comment on Required Findings

WCC Section 110.810.30, Article 810, *Special Use Permits*, requires that all of the following findings be made to the satisfaction of the Washoe County Board of Adjustment before granting approval of the request. Staff has completed an analysis of the special use permit application and has determined that the proposal is in compliance with the required findings as follows.

1. Consistency. That the proposed use is consistent with the action programs, policies, standards and maps of the Master Plan and the South Valleys Area Plan.

Staff Comment: There are no provisions within the South Valleys Area Plan that prohibit Major Grading at the subject site. Therefore, the proposed use is consistent with the action programs, policies, standards and maps of the Master Plan and the South Valleys Area Plan.

2. Improvements. That adequate utilities, roadway improvements, sanitation, water supply, drainage, and other necessary facilities have been provided, the proposed improvements are properly related to existing and proposed roadways, and an adequate public facilities determination has been made in accordance with Division Seven.

Staff Comment: The subject site has, historically, been used for commercial purposes, adequate utilities, roadway improvements, sanitation, water supply, drainage, and other necessary facilities have been provided, the proposed grading is properly related to existing and proposed roadways, and an adequate public facilities determination can be made in accordance with Division Seven, compliance with all applicable codes and provisions will be required prior to approval of a grading permit.

3. Site Suitability. That the site is physically suitable for Major Grading to to facilitate the development of an Agricultural Sales Use Type, and for the intensity of such a development.

Staff Comment: The subject site has, historically, been used for commercial purposes the regulatory zone allows Agricultural Sales Use Type and commercial uses are located on both sides of the subject site. Therefore it is the opinion of staff that the suite is suitable for the proposed use and for the intensity of that use.

4. Issuance Not Detrimental. That issuance of the permit will not be significantly detrimental to the public health, safety or welfare; injurious to the property or improvements of adjacent properties; or detrimental to the character of the surrounding area.

Staff Comment: Given careful consideration and meaningful conditions of approval, including preservation of half of the mature trees on the subject site, it is the opinion of staff that approval of the proposed special use permit will not be significantly detrimental to the public health, safety or welfare; injurious to the property or improvements of adjacent properties; or detrimental to the character of the surrounding area.

5. Effect on a Military Installation. Issuance of the permit will not have a detrimental effect on the location, purpose or mission of the military installation.

Staff Comment: There is no military installation within the area of required notice for this special use permit, therefore there is no detrimental effect anticipated.

Recommendation

Those agencies which reviewed the application recommended conditions in support of approval of the project. Therefore, after a thorough analysis and review, Special Use Permit Case Number WSUP18-0011 is being recommended for approval with conditions. Staff offers the following motion for the Board's consideration.

Motion

I move that, after giving reasoned consideration to the information contained in the staff report and information received during the public hearing, the Washoe County Board of Adjustment approve, with conditions as included at attachment A to the staff report, Special Use Permit Case Number WSUP18-0011 for Murray Ranch, LLC, having made all five findings in accordance with Washoe County Code Section 110.810.30:

1. Consistency. That the proposed use is consistent with the action programs, policies, standards and maps of the Master Plan and the South Valleys Area Plan;
2. Improvements. That adequate utilities, roadway improvements, sanitation, water supply, drainage, and other necessary facilities have been provided, the proposed improvements are properly related to existing and proposed roadways, and an adequate public facilities determination has been made in accordance with Division Seven;

- 3. Site Suitability. That the site is physically suitable for Major Grading to to facilitate the development of an Agricultural Sales Use Type, and for the intensity of such a development;
- 4. Issuance Not Detrimental. That issuance of the permit will not be significantly detrimental to the public health, safety or welfare; injurious to the property or improvements of adjacent properties; or detrimental to the character of the surrounding area;
- 5. Effect on a Military Installation. Issuance of the permit will not have a detrimental effect on the location, purpose or mission of the military installation.

Appeal Process

Board of Adjustment action will be effective 10 calendar days after the written decision is filed with the Secretary to the Board of Adjustment and mailed to the applicant, unless the action is appealed to the Washoe County Board of County Commissioners, in which case the outcome of the appeal shall be determined by the Washoe County Board of County Commissioners. Any appeal must be filed in writing with the Planning and Building Division within 10 calendar days from the date the written decision is filed with the Secretary to the Board of Adjustment and mailed to the applicant.

Applicant: Murray Ranch, LLC
Attn: Jason Murray
21000 South Virginia Street
Reno, NV 89521

Owner: Reeves Business Ventures
3451 Lisbon Ct.
Sparks, NV 8 9436

Representatives: Manhard Consulting
Attn: Karen Downs
241 Ridge Street, Suite 400
Reno, NV 89501



Conditions of Approval

Special Use Permit Case Number WSUP18-0011

The project approved under Special Use Permit Case Number WSUP18-0011 shall be carried out in accordance with the Conditions of Approval granted by the Board of Adjustment on July 11, 2018. Conditions of Approval are requirements placed on a permit or development by each reviewing agency. These Conditions of Approval may require submittal of documents, applications, fees, inspections, amendments to plans, and more. These conditions do not relieve the applicant of the obligation to obtain any other approvals and licenses from relevant authorities required under any other act.

Unless otherwise specified, all conditions related to the approval of this Special Use Permit shall be met or financial assurance must be provided to satisfy the conditions of approval prior to issuance of a grading or building permit. The agency responsible for determining compliance with a specific condition shall determine whether the condition must be fully completed or whether the applicant shall be offered the option of providing financial assurance. All agreements, easements, or other documentation required by these conditions shall have a copy filed with the County Engineer and the Planning and Building Division.

Compliance with the conditions of approval related to this Special Use Permit is the responsibility of the applicant, his/her successor in interest, and all owners, assignees, and occupants of the property and their successors in interest. Failure to comply with any of the conditions imposed in the approval of the Special Use Permit may result in the institution of revocation procedures.

Washoe County reserves the right to review and revise the conditions of approval related to this Special Use Permit should it be determined that a subsequent license or permit issued by Washoe County violates the intent of this approval.

For the purpose of conditions imposed by Washoe County, “may” is permissive and “shall” or “must” is mandatory.

Conditions of Approval are usually complied with at different stages of the proposed project. Those stages are typically:

- Prior to permit issuance (i.e., grading permits, building permits, etc.).
- Prior to obtaining a final inspection and/or a certificate of occupancy.
- Prior to the issuance of a business license or other permits/licenses.
- Some “Conditions of Approval” are referred to as “Operational Conditions.” These conditions must be continually complied with for the life of the project or business.

The Washoe County Commission oversees many of the reviewing agencies/departments with the exception of the following agencies.

- **The DISTRICT BOARD OF HEALTH, through the Washoe County Health District, has jurisdiction over all public health matters in the Health District. Any conditions set by the Health District must be appealed to the District Board of Health.**

FOLLOWING ARE CONDITIONS OF APPROVAL REQUIRED BY THE REVIEWING AGENCIES. EACH CONDITION MUST BE MET TO THE SATISFACTION OF THE ISSUING AGENCY.

Washoe County Planning and Building Division

1. The following conditions are requirements of Planning and Building, which shall be responsible for determining compliance with these conditions.

Contact Name – Roger Pelham (775) 328-3622, rpelham@washoecounty.us

- a. The applicant shall demonstrate substantial conformance to the plans approved as part of this special use permit. The Planning and Building Division shall determine compliance with this condition.
- b. The applicant shall submit complete construction plans and building permits shall be issued within two years from the date of approval by Washoe County. The applicant shall complete construction within the time specified by the building permits. Compliance with this condition shall be determined by the Planning and Building Division.
- c. Prior to final inspection of grading the applicant shall remove all vehicles, equipment, cargo containers and similar items from the subject site.
- d. Prior to final inspection of grading the applicant shall remove all refuse and debris from the subject site.
- e. The subject site shall be enclosed by a fence. The fence shall be at least six feet in height, but not greater than eight feet in height. The fence shall be chain link with slats. The slats shall provide at least 75% visual obscurity, the slats shall be at least tan, brown, sage or another color acceptable to the Director of Planning and Building that blends with the surrounding area. The fence shall be located on the property line on the north, east and west sides of the subject site. On the south side, adjacent to US Highway 395 South, the fence shall be located to the north of (behind) the proposed landscape area.
- f. The landscape area adjacent to US Highway 395 South shall comprise 20% of the subject site in accordance with Section 110.412.40(a), of the Development Code.
- g. Prior to approval of a grading permit the applicant shall provide landscape plans in accordance with section 110.412.15 of the Development Code. The plans shall show that established bushes and trees in the proposed landscape area will be preserved to the greatest extent possible.
- h. Prior to approval of a grading permit the applicant shall submit a tree preservation plan and shall maintain at least half of the existing mature trees on the subject site.
- i. All mature deciduous trees remaining on the subject site shall be pruned such that branches are at least eight feet above the ground.
- j. Reconfiguration of the location of proposed hay barns on the subject site is acceptable to accommodate the tree preservation plan.
- k. Prior to any ground disturbing activity, the applicant shall submit a landscaping and design plan to the Planning and Building Division for review and approval. Said plan shall address parking, parking lot circulation and striping, signage, exterior lighting, trash enclosures, landscaping and plant material, type and size of plants, maturation size at full growth, landscaping location, and landscaping irrigation system.

- l. Grading plans shall include revegetation of all areas disturbed by grading activities, not utilized by the proposed commercial use. Revegetation shall include tree seeds of the type common to the subject site.
- m. Grading plans shall include barriers along the entire perimeter of the truck maneuvering area to inhibit vehicular access to undeveloped and revegetated areas. Barriers shall include boulders (at least 24 inches in diameter), bollards or other items acceptable to the Director of Planning and Building. Barriers shall be placed such that gaps between the barriers are 48 inches or less.
- n. Construction activities shall take place only between the hours of 7:00 a.m. and 7:00 p.m.
- o. A note shall be placed on all construction drawings and grading plans stating:

NOTE

Should any cairn or grave of a Native American be discovered during site development, work shall temporarily be halted at the specific site and the Sheriff's Office as well as the State Historic Preservation Office of the Department of Conservation and Natural Resources shall be immediately notified per NRS 383.170.

Washoe County Engineering and Capital Projects

2. The following conditions are requirements of the Engineering Division, which shall be responsible for determining compliance with these conditions.

Contact Name – Leo Vesely (775) 328-2041, ivesely@washoecounty.us

- a. A complete set of construction improvement drawings, including an on-site grading plan, shall be submitted when applying for a building/grading permit. Grading shall comply with best management practices (BMP's) and shall include detailed plans for grading, site drainage, erosion control (including BMP locations and installation details), slope stabilization, and mosquito abatement. Placement or removal of any excavated materials shall be indicated on the grading plan. Silts shall be controlled on-site and not allowed onto adjacent property.
- b. For construction areas larger than 1 acre, the developer shall obtain, from the Nevada Division of Environmental Protection, a Stormwater Discharge Permit and submit a copy to the Engineering Division prior to issuance of a grading permit.
- c. The Truckee Meadows Regional Stormwater Quality Management Program Construction Permit Submittal Checklists and Inspection Fee shall be submitted with the grading permit.
- d. A grading bond of \$2,000/acre of disturbed area shall be provided to the Engineering Division prior to any grading.
- e. Cross-sections indicating cuts and fills shall be submitted, when applying for a grading permit. Estimated total volumes shall be indicated.
- f. All disturbed areas left undeveloped for more than 30 days shall be treated with a dust palliative. Disturbed areas left undeveloped for more than 45 days shall be revegetated. Specifications for revegetation procedure and seed mix shall be prepared by a licensed landscape architect.

DRAINAGE (COUNTY CODE 110.416, 110.420, and 110.421)

- g. A detailed hydrology/hydraulic report prepared by a licensed engineer shall be submitted to the Engineering Division for review and approval. The report shall include the locations, points of entry and discharge, flow rates and flood limits of all 5- and 100-year storm flows impacting both the site and offsite areas and the methods for handling those flows. The report shall include all storm drain pipe and ditch sizing calculations and a discussion of and mitigation measures for any impacts on existing offsite drainage facilities and properties.
- h. Any increase in peak stormwater runoff flow rate resulting from the development and based on the 5 year and 100 storm(s) shall be detained onsite.
- i. The 100-year floodplain boundaries and flood zones shall appear on the grading plan. All grading and construction in these areas shall be in conformance with the Washoe County Code Article 416.
- j. The following note shall be added to the grading plan; "All properties, regardless if they are located within or outside of a FEMA designated flood zone, may be subject to flooding. The property owner is required to maintain all drainage easements and natural drainages and not perform or allow unpermitted and unapproved modifications to the property that may have detrimental impacts to surrounding properties."

*** End of Conditions ***

From: [Lawson, Jacqueline](#)
To: [Pelham, Roger](#)
Cc: [Dayton, Brittany](#)
Subject: May Agency Review Memo II
Date: Wednesday, May 30, 2018 4:28:32 PM

Hello Roger,

The EMS Program does not have any comments for Special Use Permit Case Number WSUP18-0011 (Murry Grading) included in May Agency Review Memo II (item 2).

The EMS Program also does not have any comments for Special Use permit Case Number WSUP18-0012 (Lemmon Drive Estates) included in May Agency Review Memo II (item 3).

Please let me know if you have any questions.

Thank you

Jackie

Jackie Lawson

Office Support Specialist | Emergency Medical Services and Public Health Preparedness
Washoe County District Health District
jlawson@washoecounty.us | O: (775) 326-6051
1001 E. Ninth St., Bldg. B, Reno, NV 89512

From: [Schull, Shyanne](#)
To: [Pelham, Roger](#)
Subject: WSUP18-0011 (Murry Grading)
Date: Friday, May 25, 2018 3:39:10 PM
Attachments: [image003.png](#)

Roger,

WCRAS does not have any concerns relative to the above mentioned application.

Shyanne Schull
Director
Washoe County Regional Animal Services
2825A Longley Lane
Reno, NV 89502
775.328.2142 Office
775.322.3647 Dispatch
Sschull@washoecounty.us
www.washoeanimals.com

"Promoting responsible care of animals through education, proactive outreach, and regulation, making Washoe County a safe community".





REGIONAL TRANSPORTATION COMMISSION

Metropolitan Planning · Public Transportation & Operations · Engineering & Construction

Metropolitan Planning Organization of Washoe County, Nevada

May 23, 2018

FR: Chrono/PL 183-18

Mr. Roger Pelham, Senior Planner
Community Services Department
Washoe County
PO Box 11130
Reno, NV 89520

RE: WSUP18-0011 (Murry Grading)

Dear Mr. Pelham,

We have reviewed the subject application and have the following comments and recommendations.

Comments and Recommendations:

1. The Regional Transportation Plan identifies South Virginia Street as an arterial with high-access control. To maintain arterial capacity, the following RTP access management standards should be maintained.

Access Management Standards-Arterials ¹ and Collectors							
Access Management Class	Posted Speeds	Signals Per Mile and Spacing ²	Median Type	Left From Major Street? (Spacing from signal)	Left From Minor Street or Driveway?	Right Decel Lanes at Driveways?	Driveway Spacing ³
High Access Control	45-55 mph	2 or less Minimum spacing 2350 feet	Raised w/channelized turn pockets	Yes 750 ft. minimum	Only at signalized locations	Yes ⁴	250 ft./500 ft.

¹ On-street parking shall not be allowed on any new arterials. Elimination of existing on-street parking shall be considered a priority for major and minor arterials operating at or below the policy level of service.

² Minimum signal spacing is for planning purposes only; additional analysis must be made of proposed new signals in the context of planned signalized intersections, and other relevant factors impacting corridor level of service.

³ Minimum spacing from signalized intersections/spacing other driveways.

⁴ If there are more than 30 inbound, right-turn movements during the peak-hour.

2. The policy Level of Service (LOS) standard for South Virginia Street is LOS D and Greg Street is LOS D. Policy LOS for intersections shall be designed to provide a level of service consistent with maintaining the policy level of service of the intersection corridor. This project should be required to meet all the conditions necessary to complete road improvements to maintain policy LOS standards.
3. Per the RTC Access Management Standards, driveway access on high access control arterials are limited to right in/right out and left in movements at non-signalized locations. However, this corridor is maintained by the Nevada Department of Transportation and has numerous full movement driveways. There are currently no plans to restrict access, but it could be recommended in the future.

RTC Board: Ron Smith (Chair) · Bob Lucey (Vice Chair) · Paul McKenzie · Vaughn Hartung · Neoma Jardon
PO Box 30002, Reno, NV 89520 · 1105 Terminal Way, Reno, NV 89502 · 775-348-0400 · rtcwashoe.com

4. The RTP, RTC Bicycle/Pedestrian Master Plan and the Nevada Department of Transportation Pedestrian Safety Action Plan, all indicate that new development and re-development will be encouraged to construct pedestrian and bicycle facilities, internal and/or adjacent to the development, within the regional road system. Also, these plans recommend that the applicant be required to design and construct any sidewalks along the frontage of the property in conformance with the stated ADA specifications.

Thank you for the opportunity to comment on this application. Please feel free to contact me at 775-332-0174 or email me at rkapuler@rtcwashoe.com if, you have any questions or comments.

Sincerely,



Rebecca Kapuler
Planner

RK/jm

Copies: Mojra Hauenstein, Washoe County Community Services
Trevor Lloyd, Washoe County Community Services
Jae Pullen, Nevada Department of Transportation, District II
Daniel Doenges, Regional Transportation Commission
Tina Wu, Regional Transportation Commission
Mark Maloney, Regional Transportation Commission
Julie Masterpool, Regional Transportation Commission
David Jickling, Regional Transportation Commission

/461 murry grading



WASHOE COUNTY
COMMUNITY SERVICES DEPARTMENT
Engineering and Capital Projects

1001 EAST 9TH STREET
PO BOX 11130
RENO, NEVADA 89520-0027
PHONE (775) 328-3600
FAX (775) 328.3699

Date: June 11, 2018
To: Roger Pelham, Planning and Building Division
From: Leo R. Vesely, P.E., Engineering and Capitol Projects Division
Re: Murry Ranch SUP for Grading - WSUP18-0011
APN 046-080-03

GENERAL PROJECT DISCUSSION

Washoe County Engineering and Capital Project staff has reviewed the above referenced application for major grading. The proposed project consists of grading for a proposed Agricultural Sales Facility consisting of 3 pole barns (4,800 sf each) and a 600 sf sales office. The Engineering and Capital Projects Division recommends approval with the following comments and conditions of approval which supplement applicable County Code and are based upon our review of the site and the special use permit application prepared by Manhard Consulting. The County Engineer shall determine compliance with all the following conditions of approval.

For questions related to sections below, please see the contact name provided.

GENERAL CONDITIONS

Contact Information: Leo R. Vesely, P.E. (775) 328-2041

1. A complete set of construction improvement drawings, including an on-site grading plan, shall be submitted when applying for a building/grading permit. Grading shall comply with best management practices (BMP's) and shall include detailed plans for grading, site drainage, erosion control (including BMP locations and installation details), slope stabilization, and mosquito abatement. Placement or removal of any excavated materials shall be indicated on the grading plan. Silts shall be controlled on-site and not allowed onto adjacent property.
2. For construction areas larger than 1 acre, the developer shall obtain from the Nevada Division of Environmental Protection a Stormwater Discharge Permit and submit a copy to the Engineering Division prior to issuance of a grading permit.
3. The Truckee Meadows Regional Stormwater Quality Management Program Construction Permit Submittal Checklists and Inspection Fee shall be submitted with the grading permit.
4. A grading bond of \$2,000/acre of disturbed area shall be provided to the Engineering Division prior to any grading.
5. Cross-sections indicating cuts and fills shall be submitted when applying for a grading permit. Estimated total volumes shall be indicated.



INTEGRITY



EFFECTIVE
COMMUNICATION



QUALITY
PUBLIC SERVICE

WWW.WASHOECOUNTY.NV

Subject: Murry Ranch SUP for Grading - WSUP18-0011
Date: June 6, 2018
Page: 2

6. All disturbed areas left undeveloped for more than 30 days shall be treated with a dust palliative. Disturbed areas left undeveloped for more than 45 days shall be revegetated. Specifications for revegetation procedure and seed mix shall be prepared by a licensed landscape architect.

DRAINAGE (COUNTY CODE 110.416, 110.420, and 110.421)

Contact Information: Leo R. Vesely, P.E. (775) 328-2041

1. A detailed hydrology/hydraulic report prepared by a licensed engineer shall be submitted to the Engineering Division for review and approval. The report shall include the locations, points of entry and discharge, flow rates and flood limits of all 5- and 100-year storm flows impacting both the site and offsite areas and the methods for handling those flows. The report shall include all storm drain pipe and ditch sizing calculations and a discussion of and mitigation measures for any impacts on existing offsite drainage facilities and properties.
2. Any increase in peak stormwater runoff flow rate resulting from the development and based on the 5 year and 100 storm(s) shall be detained onsite.
3. The 100-year floodplain boundaries and flood zones shall appear on the grading plan. All grading and construction in these areas shall be in conformance with the Washoe County Code Article 416.
4. The following note shall be added to the grading plan; "All properties, regardless if they are located within or outside of a FEMA designated flood zone, may be subject to flooding. The property owner is required to maintain all drainage easements and natural drainages and not perform or allow unpermitted and unapproved modifications to the property that may have detrimental impacts to surrounding properties."

TRAFFIC AND ROADWAY (COUNTY CODE 110.436)

Contact Information: Clara Lawson, P.E. (775) 328-3603

Discussion

The new barns and office are subject to Regional Road Impact Fees (RRIF). It is the responsibility of the applicant to provide proof of prior uses on the property with respect to the RRIF. Documented prior uses will be used as a credit towards the RRIF fee for the proposed use. The project appears to be a retail use. As the barns are for storing hay, the RRIF will likely be based on the office, or a portion of the office that's open to customers.

There are no traffic related conditions of approval.

Subject: Murry Ranch SUP for Grading - WSUP18-0011
Date: June 6, 2018
Page: 3

UTILITIES (County Code 422 & Sewer Ordinance)

Contact Information: Tim Simpson, P.E. (775) 954-4648

There are no utility related conditions of approval

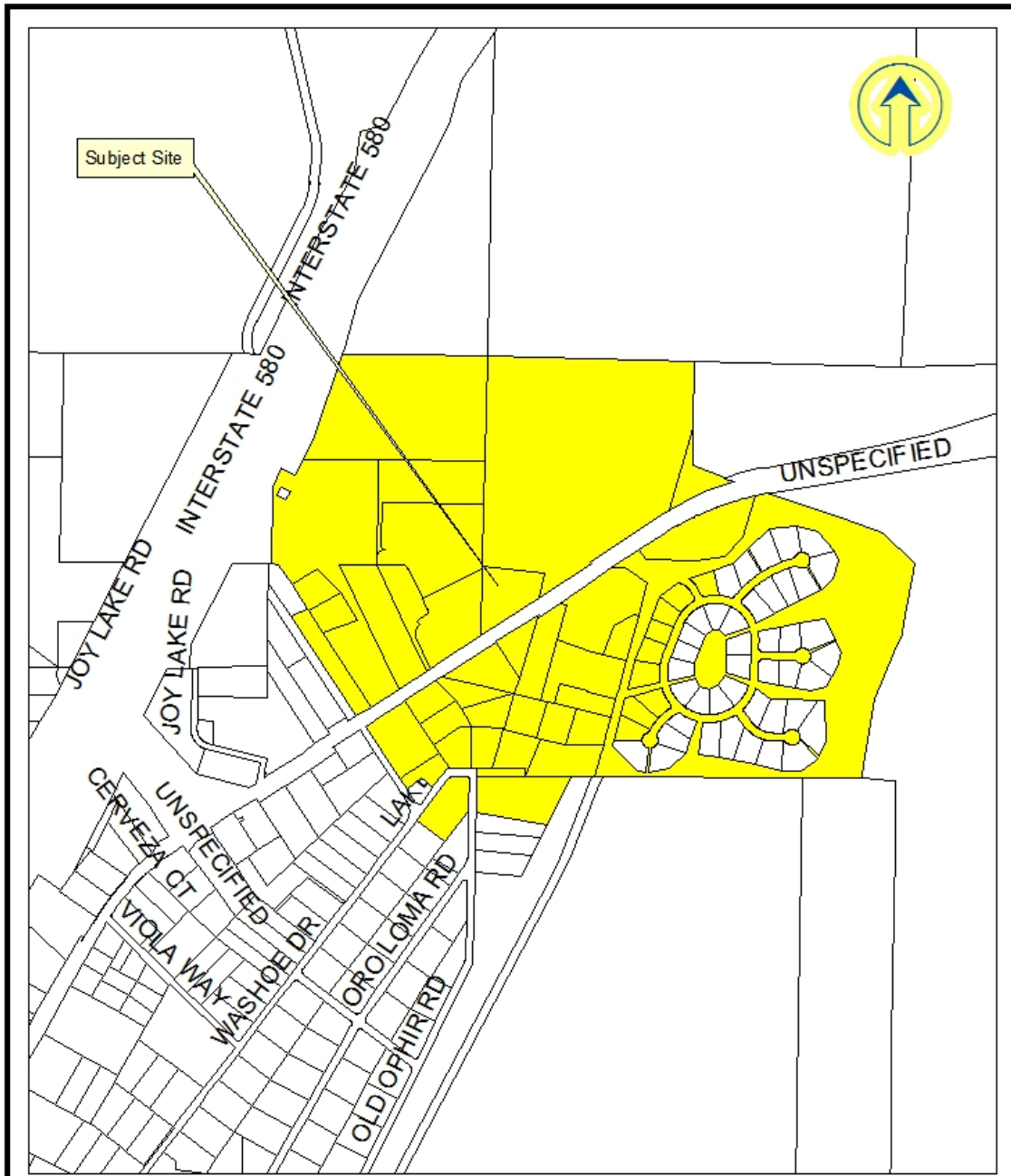

Mailing Label Map
 Special Use Permit Case Number
 WSUP18-0011 (Murray Grading)

Community Services
 Department
 Planning and
 Development Division
 WASHOE COUNTY
 NEVADA
 Post Office Box 11120
 Reno, Nevada 89520
 (775) 328-2600

Source: Planning and Building Division
 47 Parcels selected at 900 feet.
 Date: May 2018

225 US Highway 395 S

Special Use Permit- Grading
Director's Modification of Standards

May 2018



Prepared For:

Murry Ranch, LLC

21000 South Virginia
Reno, NV 89521

Prepared By:



Manhard.
CONSULTING

241 Ridge Street, Suite 400 Reno, NV 89501

WSUP18-0011
EXHIBIT D

TABLE OF CONTENTS

PROJECT LOCATION	1
EXISTING CONDITIONS.....	2
MASTER PLAN AND ZONING DESIGNATIONS	2
APPLICATION REQUEST.....	5
PROJECT DESCRIPTION.....	5
SPECIAL USE PERMIT FINDINGS	11

LIST OF FIGURES

Figure 1: Project Location	1
Figure 2: Surrounding Property Designation	2
Figure 3: Existing Conditions.....	2
Figure 4: Washoe County Master Plan Designation	3
Figure 5: Washoe County Zoning Designation.....	4
Figure 6: Project Summary.....	5
Figure 7: Site Plan	6
Figure 8: Conceptual Office Building Design.....	7
Figure 9: Conceptual Pole Barn Design.....	7
Figure 10: Development Standards	8
Figure 11a: Conceptual Sign Design.....	9
Figure 11b: Conceptual Driveway Entrance Arch	9

APPENDICES

- SUP for Grading Application with Affidavit
- Director’s Modification of Standards Application with Affidavit
- Proof of Property Tax Payment
- Title Report (original packet only)
- Plan Set
- Building Elevations

PROJECT LOCATION

The 2.53 acre project site (APN 046-080-03) is located in Washoe Valley west of US Highway 395 S, approximately 1 mile south of Eastlake Boulevard.

Figure 1: Project Location

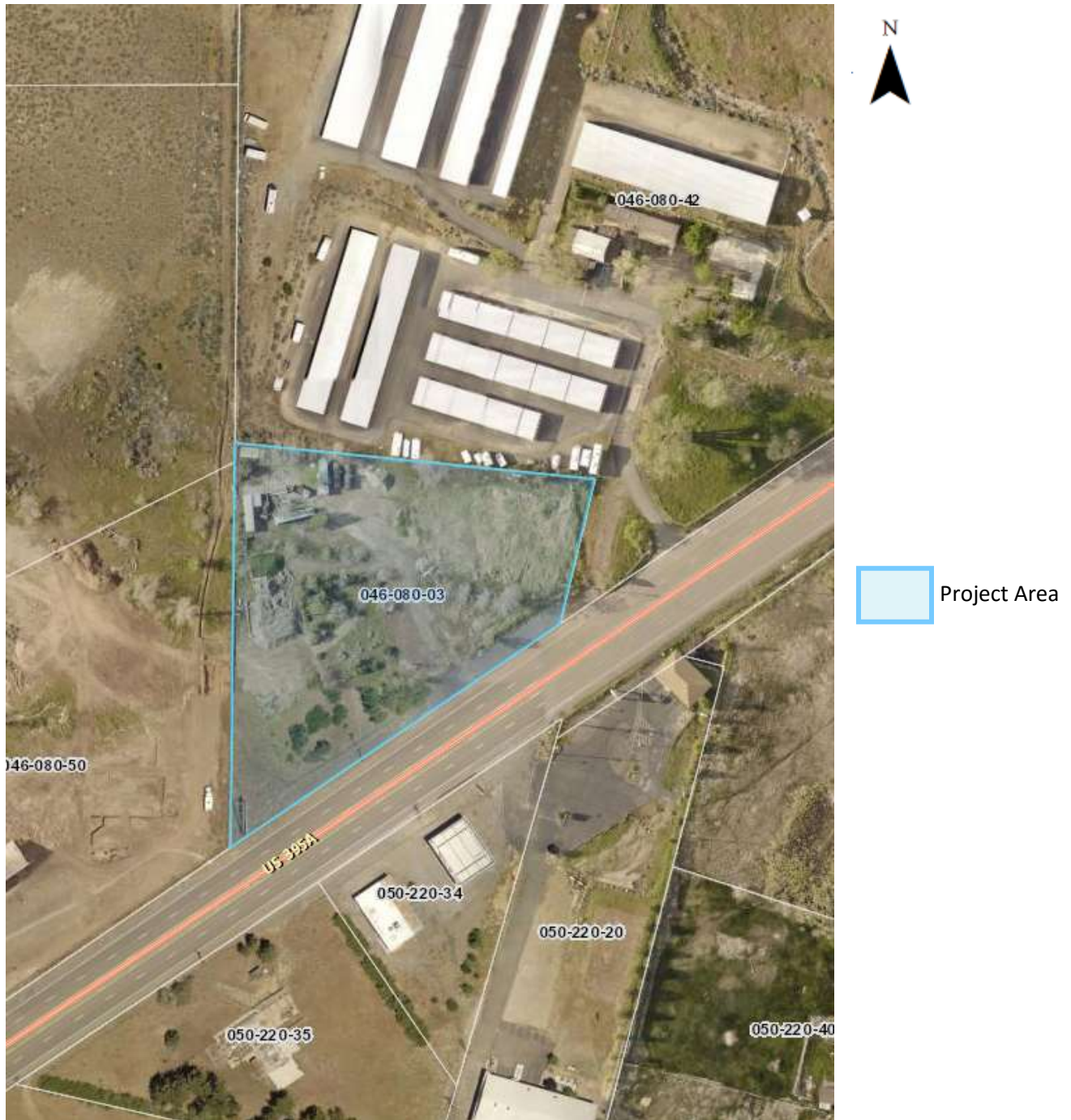

EXISTING CONDITIONS

The project site is currently undeveloped. The site was previously developed as a commercial use, until the building was demolished in 2003.

Figure 2: Surrounding Property Designations

Direction	Current Zoning	Master Plan	Current Land Use
North	General Commercial	Commercial	Commercial (mini-storage)
East	General Commercial	Commercial	Commercial (mini-storage)
South	General Commercial	Commercial	Commercial (Washoe Valley Plaza, Gas Station)
West	General Commercial	Commercial	Commercial (nursery)

Figure 3: Existing Conditions



MASTER PLAN AND ZONING DESIGNATIONS

The project site has a Master Plan designation of Commercial and a zoning designation of General Commercial.



Figure 4: Washoe County Master Plan Designation

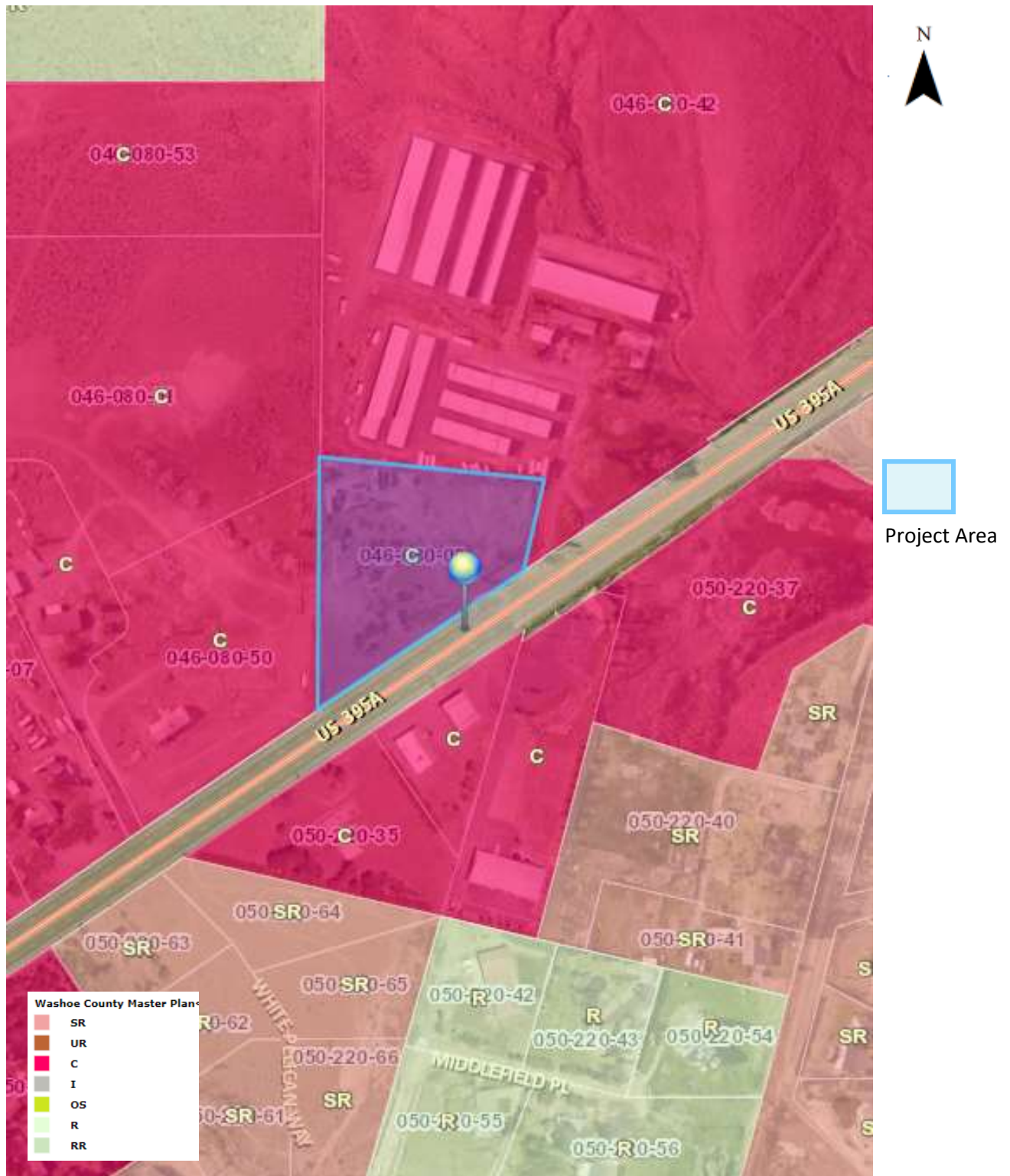
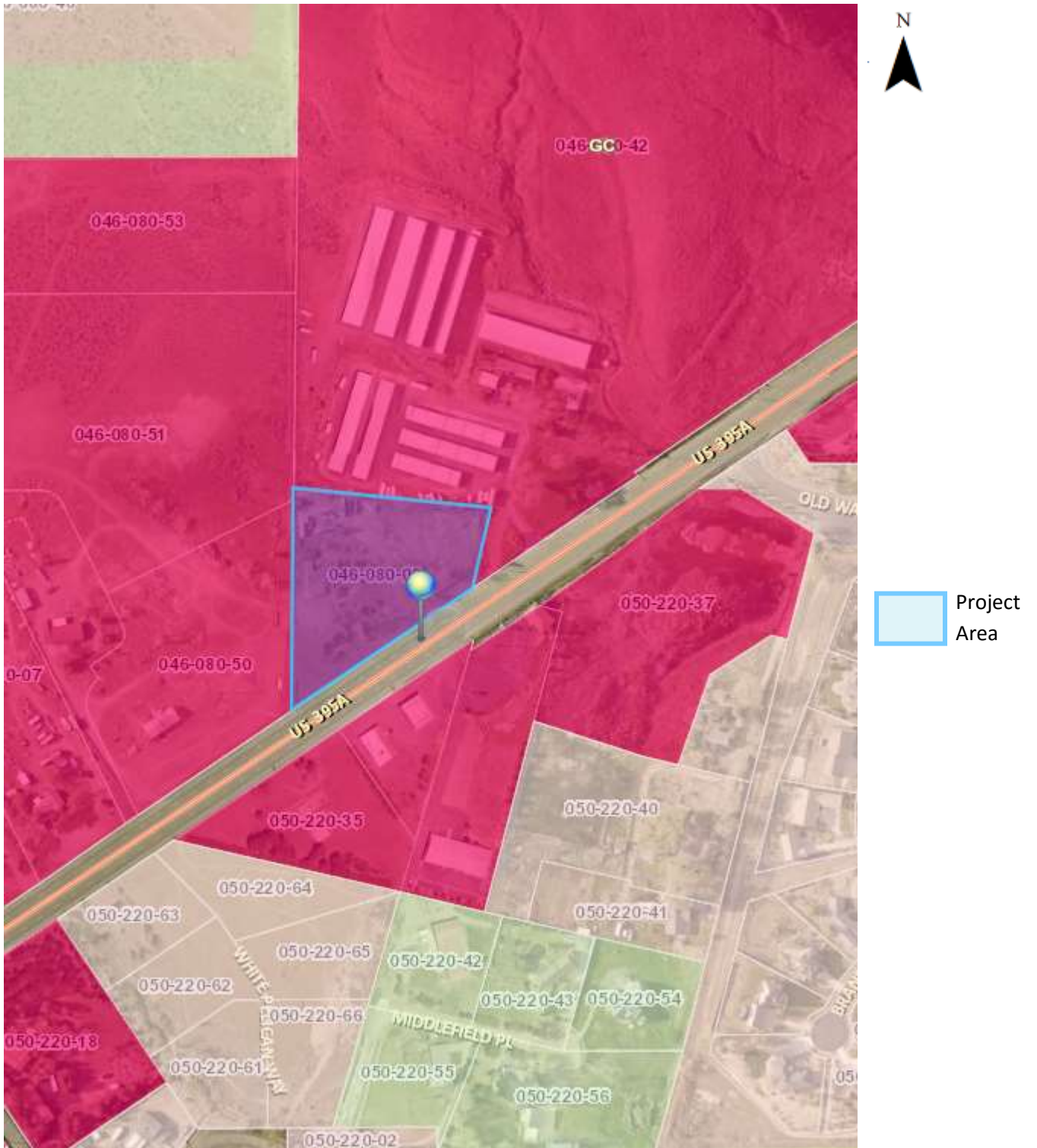

Figure 5: Washoe County Zoning Designation



APPLICATION REQUEST

The enclosed application is a request for:

1. **SPECIAL USE PERMIT FOR GRADING** of an area of one acre or more on a parcel less than six acres in size in accordance with Washoe County Development Code Article 438, Grading Standards.
2. **DIRECTOR'S MODIFICATION OF PARKING/LANDSCAPING STANDARDS** to allow for compacted aggregate base material in lieu of asphalt paving for a loading and work area.

PROJECT DESCRIPTION

The Special Use Permit for Grading is for proposed grading of an area of one acre or more on a parcel less than six acres in size. The purpose of the grading is to allow for development of the project site as an agricultural use, which will include three pole barns (4,800 sq. ft. each) and a +/- 600 sq. ft. office building. The proposed site will be used for agricultural sales for Murry Ranch.

Director's Modification of Parking/Landscaping Standards

The Director's Modification of Parking/Landscaping Standards is to allow for compacted aggregate base material in lieu of asphalt paving in the loading and work areas adjacent to the barns. This will allow the agricultural operations to flow more smoothly by having a compacted aggregate base surface that is more conducive to agricultural equipment, and loading and unloading activities. Furthermore, if the area had asphalt surfacing, the maneuvering and operation of the agricultural equipment would cause cracks in the asphalt, and ultimately failure of the surface. The "Director's Modification of Standards Parking/Landscape Application Supplemental Information" form is attached.

Figure 6: Project Summary

Project Summary	
Total Area	2.53 acres
Disturbed Area	+/- 80,000 sq. ft.
Amount of Import	+/- 5,400 cu. yards
Slope	Maximum 3:1 slope
Flood Zone	A majority of the site is located in Flood Zone A

Site Plan

The Site Plan includes three 4,800 sq. ft. pole barns adjacent to a truck maneuvering area for loading and unloading trailers east of the barns, with compacted aggregate base material. There is also a +/- 600 sq.



ft. office building, with a 6-stall paved parking area. There is driveway access to the site from U.S. Highway 395 South. A landscape area is proposed along U.S. Highway 395.

Figure 7: Site Plan

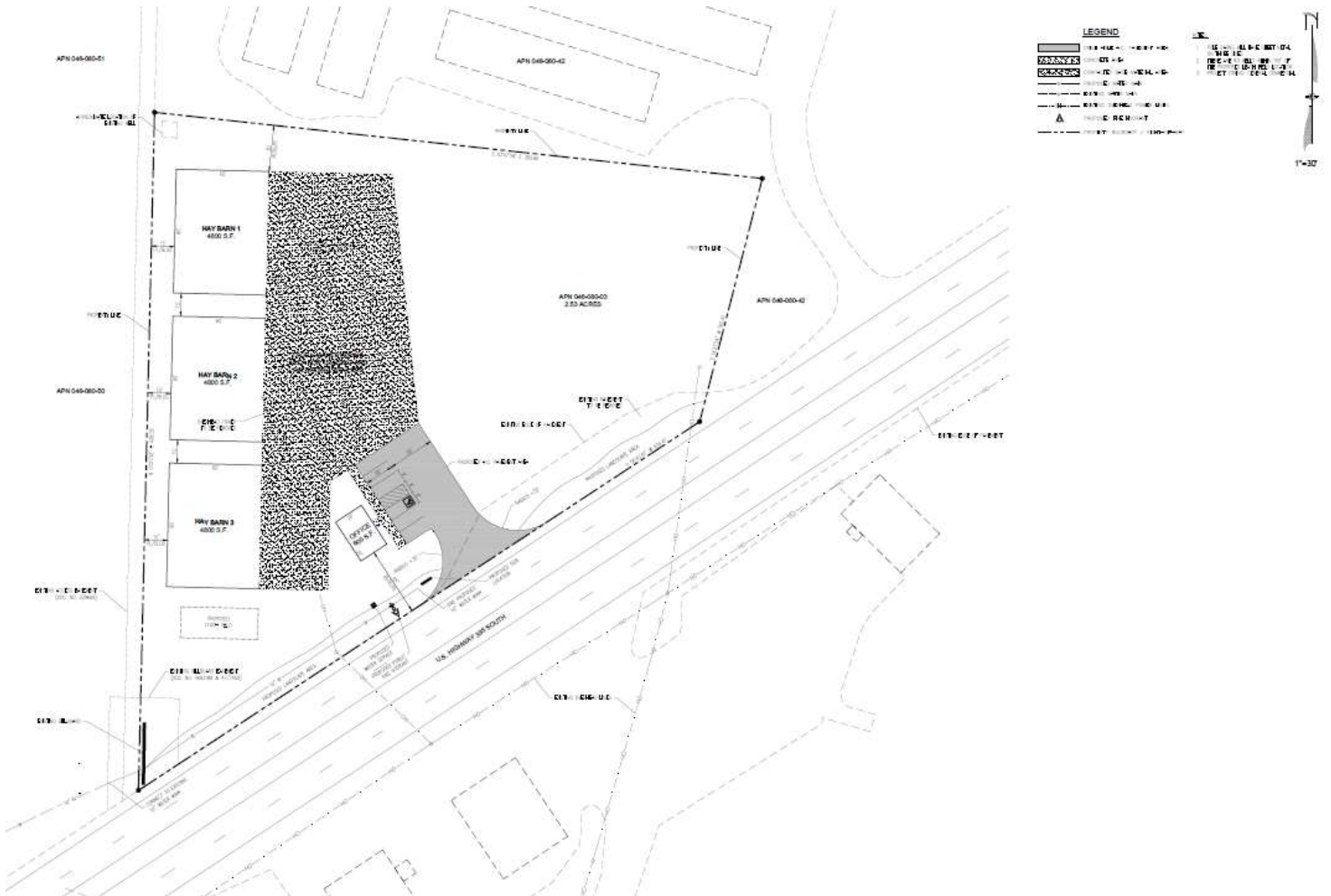

Building Elevations

The proposed office building is +/- 600 sq. ft. The conceptual design is shown in Figure 8, Conceptual Office Building. The building has a single-story, ranch design, with a porch. Finish materials are not yet determined.

Building elevations for the three pole barns are included as an exhibit, and shown in Figure 9. They are three-sided barns, with an open side to allow for hay storage in a dry, well-ventilated facility.



Figure 8: Conceptual Office Building Design



Figure 9: Conceptual Pole Barn Design

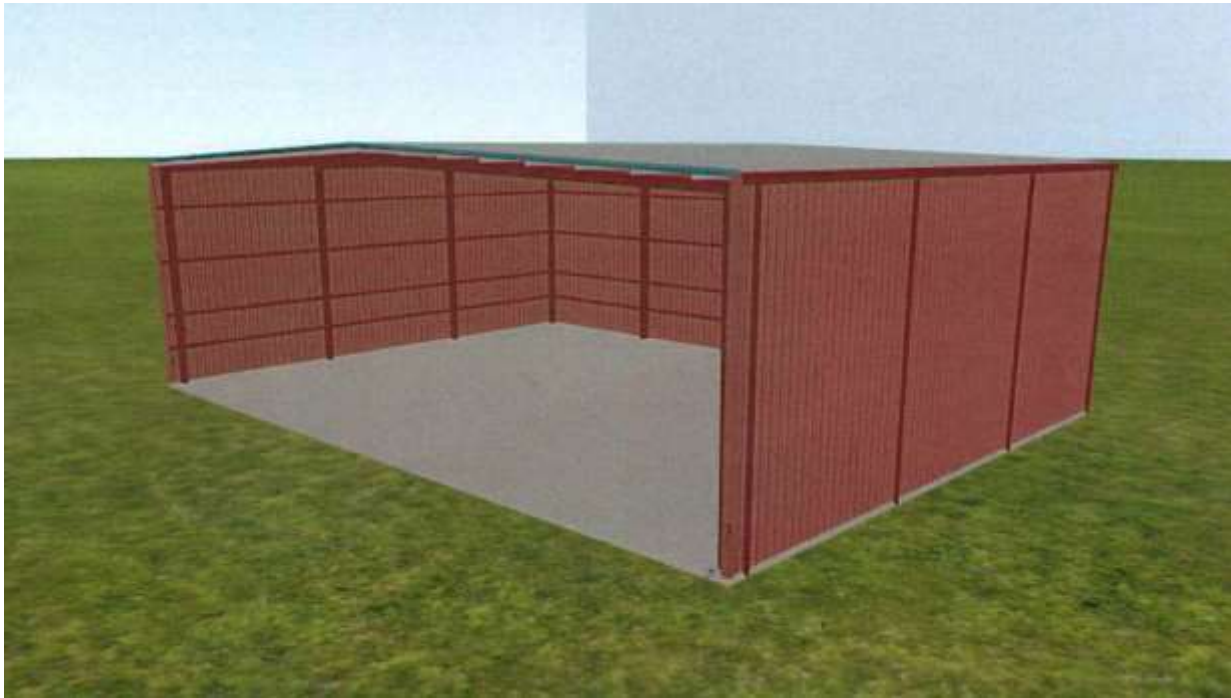

Business Activity

Daily operations at Murry Ranch include hay delivery. The hay is loaded with a hay squeeze (a piece of equipment that squeezes that bottom of a stack of bales, picks up the stacks, and moves it to the desired location). Six standard-size trucks are used for deliveries. In addition, there are +/- 3 semi-truck deliveries per week to the hay yard. The semi-trucks are unloaded with a hay squeeze.

Murry Ranch includes a 100-acre farm in a separate in Washoe County location, which provides hay for livestock. Current hours of Murry Ranch are Tuesday through Friday from approximately 7:30 a.m. to 5:00 p.m. and Saturday from 10:00 a.m. to 4:00 p.m., including hay delivery operations. There are typically 10-15 customers per day. Sales include agricultural and ranch-related products.

There are two employees who work in the morning delivering hay and in the hay yard, using agricultural equipment. There is one employee who will primarily work in the office, and Mr. Murry, who works at various Murry Ranch locations, which will include the proposed site at 225 US Highway 395S.

Development Standards

The proposed project meets the standards for General Commercial, set forth in Table 110.406.05.1.

Figure 10: Development Standards

	Code Requirement	Proposed/Existing Conditions
Building Height	Maximum 80 feet	19'6" proposed
Minimum Lot Area	10,000 sq. ft.	existing lot is 2.53 acres
Minimum Lot Width	75 feet	existing width is +/- 394 feet
Front Yard Setback	10 feet	45 feet proposed
Side Yard Setback	10 feet	15 feet proposed
Rear Yard Setback	10 feet	30 feet proposed

Signage

As shown on the Site Plan, the applicant proposes a freestanding sign located west of the driveway entrance. The sign will meet Washoe County Development Code Division 5, related to Agricultural Uses. It will have a maximum height of 6 feet and maximum sign size of 16 sq. ft. (Table 110.505.15.1), and have a conceptual design as shown in Figure 11a.



Figure 11a: Conceptual Sign Design



If permitted, the applicant would like to install a decorative arch over the driveway entrance. The conceptual design in shown in Figure 11b.

Figure 11b: Conceptual Driveway Entrance Arch



Lighting

All exterior lighting will meet Washoe County Development Code standards, Section 110.410.25 (g).



Parking

The project will meet the parking requirements of Article 410, Parking and Loading. Off-street parking will be provided through a parking lot located adjacent to the office building. The design meets the Off-Street Parking Space Requirements (Agricultural Use Types) in Table 110.410.10.5; 3 spaces per 1,000 square feet of building space plus 1 per employee during peak employment shift (2 employees). Based on these requirements, five spaces (3 spaces for the +/- 600 sq. ft. office building plus 2 spaces for employees) are required. Six spaces, including 1 accessible space, are shown on the Site Plan.

As discussed on Page 6, a Director's Modification of Parking Standards is included as part of this application. It is requested that compacted aggregate base be allowed in lieu of asphalt paving the loading areas around the barns. This will allow the agricultural operations to flow more smoothly by having a compacted aggregate base surface that is more conducive to agricultural equipment, and loading and unloading activities. Furthermore, if the area had asphalt surfacing, the maneuvering and operation of the agricultural equipment would cause cracks in the asphalt, and ultimately failure of the surface.

Landscaping

Landscaping will be provided in accordance with Article 412, Landscaping, Section 110.412.45 Industrial and Agricultural Use Types and Section 110.412.50 Parking and Loading Areas. A landscaped area is provided along US Highway 395 frontage. Every attempt will be made to preserve the existing on-site trees.

Utilities

Water will be provided through TMWA. A connection to the existing 10" water main will be located in the southwest corner of the property. A septic tank will be provided for the office building. The proposed leach field will be located in the undeveloped area south of the barns.

Flood Zone

As depicted on the Site Plan, a majority of the site is located in Flood Zone A. The finished floors of the three barns and the office building have been designed to be two feet higher than the undisturbed ground. This requires the import of materials.

Construction and Revegetation

During construction, a chain link fence with fabric will be used to mitigate the visual aspects of construction. Water trucks will provide temporary irrigation to the disturbed area. A weed-free seed mix will be used, which will consist of Mountain Brome, Sandberg Bluegrass, Thickspike Wheatgrass, Pubescent Wheatgrass, Big Bluegrass, Big Sagebrush, Bitterbrush, Silverleaf Lupine, Blue Flax, and Louisiana Sagebrush with 20.15 pounds per acre broadcasted.



SPECIAL USE PERMIT FINDINGS

The project has been designed to meet the Special Use Permit Findings in Section 110.810.30.

- (a) Consistency. The proposed use is consistent with the action programs, policies, standards, and maps of the Master Plan and the applicable area plan;**

The proposed use (Agricultural Sales) and Site Plan is consistent with the current Master Plan designation of Commercial and zoning designation of General Commercial. The project meets applicable goals and policies of the Washoe County Master Plan and the South Valleys Area Plan.

- (b) Improvements. Adequate utilities, roadway improvements, sanitation, water supply, drainage, and other necessary facilities have been provided, the proposed improvement are properly related to existing and proposed roadways, and an adequate public facilities determination has been made in accordance with Division Seven;**

Utilities for the proposed project will be adequately served through TMWA, septic tank, US Highway 395. The site has been designed to have adequate drainage. Proposed improvements are related to US Highway 395, utilizing the existing driveway location.

- (c) Site Suitability. The site is physically suitable for the type of development and for the intensity of development;**

The site is physically for this type of agricultural use. There are no slope issues. And the finished floors are constructed to be 2 feet above the undisturbed ground.

- (d) Issuance Not Detrimental. The proposed use is consistent with the action programs, policies, standards, and maps of the Master Plan and the applicable area plan;**

In accordance with Article 702, Adequate Public Facilities Management System, public infrastructure is provided that is necessary to support this development project. It will be available concurrently with the impacts of the development that will not cause the level of service at which the infrastructure is provided to fall below adopted standards. All necessary utilities are currently in place or will be in place to adequately serve the proposed project. Any new infrastructure improvements will be constructed to Washoe County standards and will be paid for by the developer.

- (e) Effect on a Military Installation. Issuance of the permit will not have a detrimental effect on the location, purpose or mission of the military installation;**

N/A. The proposed subdivision is not located to have an effect on a military installation.



Community Services Department

Planning and Building

SPECIAL USE PERMIT

(see page 5)

SPECIAL USE PERMIT FOR GRADING

(see page 11)

SPECIAL USE PERMIT FOR STABLES

(see page 16)

APPLICATION



Community Services Department
Planning and Building
1001 E. Ninth St., Bldg. A
Reno, NV 89520

Telephone: 775.328.6100

Washoe County Development Application

Your entire application is a public record. If you have a concern about releasing personal information, please contact Planning and Building staff at 775.328.6100.

Project Information		Staff Assigned Case No.: _____	
Project Name: 225 US Highway 395 S			
Project Description: SUP for Grading for development of three pole barns and a +/- 600 sq. ft. office building.			
Project Address: 225 US Highway 395 S, Washoe Valley, NV 89704			
Project Area (acres or square feet): 2.53 acres			
Project Location (with point of reference to major cross streets AND area locator): Located on US Highway 395 S, approximately .8 miles southwest of Eastlake Boulevard.			
Assessor's Parcel No.(s):	Parcel Acreage:	Assessor's Parcel No.(s):	Parcel Acreage:
046-080-03	2.53 acres		
Section(s)/Township/Range: Section 24 Township 17 Range 19			
Indicate any previous Washoe County approvals associated with this application: Case No.(s). N/A (submitted concurrently with a Director's Modification Application)			
Applicant Information (attach additional sheets if necessary)			
Property Owner:		Professional Consultant:	
Name: Reeves Business Ventures		Name: Manhard Consulting	
Address: 3451 Lisbon Ct. Sparks, NV		Address: 241 Ridge St, Suite 400, Reno, NV	
Zip: 89436		Zip: 89501	
Phone:	Fax:	Phone: 775-321-6538	Fax:
Email:		Email: kdowns@manhard.com	
Cell:	Other:	Cell: 775-313-3360	Other:
Contact Person:		Contact Person: Karen Downs	
Applicant/Developer:		Other Persons to be Contacted:	
Name: Murry Ranch, LLC		Name:	
Address: 21000 South Virginia, Reno NV		Address:	
Zip: 89521		Zip:	
Phone:	Fax:	Phone:	Fax:
Email: hayjay1955@gmail.com		Email:	
Cell:	Other:	Cell:	Other:
Contact Person: Jason Murry		Contact Person:	
For Office Use Only			
Date Received:	Initial:	Planning Area:	
County Commission District:		Master Plan Designation(s):	
CAB(s):		Regulatory Zoning(s):	

Special Use Permit Application for Grading Supplemental Information

(All required information may be separately attached)

Chapter 110 of the Washoe County Code is commonly known as the Development Code. Specific references to special use permits may be found in Article 810, Special Use Permits. Article 438, Grading, and Article 418, Significant Hydrologic Resources, are the ordinances specifically involved in this request.

1. What is the purpose of the grading?

The purpose of the grading is to construct three pole barns, one +/- 600 sq. ft. office building, and other proposed improvements on the project site.

2. How many cubic yards of material are you proposing to excavate on site?

0

3. How many square feet of surface of the property are you disturbing?

+/- 80,000 sq. ft.

4. How many cubic yards of material are you exporting or importing? If none, how are you managing to balance the work on-site?

There will be +/- 5,400 cubic yards of import.

5. Is it possible to develop your property without surpassing the grading thresholds requiring a Special Use Permit? (Explain fully your answer.)

No. With the proposed development, the disturbed surface area threshold was surpassed. The site is in Flood Zone A and the buildings' finished floors needed to be two feet higher than the undisturbed ground, which requires the import of materials.

6. Has any portion of the grading shown on the plan been done previously? (If yes, explain the circumstances, the year the work was done, and who completed the work.)

No

7. Have you shown all areas on your site plan that are proposed to be disturbed by grading? (If no, explain fully your answer.)

Yes

8. Can the disturbed area be seen from off-site? If yes, from which directions, and which properties or roadways?

Yes. The disturbed area will be seen from the properties directly west, north, and east, and from US Highway 395 S to the south.

9. Could neighboring properties also be served by the proposed access/grading requested (i.e. if you are creating a driveway, would it be used for access to additional neighboring properties)?

No

10. What is the slope (Horizontal/Vertical) of the cut and fill areas proposed to be? What methods will be used to prevent erosion until the revegetation is established?

A maximum 3:1 slope will be used for fill slopes. Straw bale sediment barriers will be the method used to prevent erosion.

11. Are you planning any berms?

<input type="checkbox"/> Yes	<input checked="" type="checkbox"/> No	If yes, how tall is the berm at its highest?
------------------------------	--	--

12. If your property slopes and you are leveling a pad for a building, are retaining walls going to be required? If so, how high will the walls be and what is their construction (i.e. rockery, concrete, timber, manufactured block)?

N/A

13. What are you proposing for visual mitigation of the work?

A chain link fence with fabric will be used to mitigate the visual aspects of construction.

14. Will the grading proposed require removal of any trees? If so, what species, how many and of what size?

Yes. Approximately 16 deciduous trees with trunks less than 12 inches in diameter will be removed.

15. What type of revegetation seed mix are you planning to use and how many pounds per acre do you intend to broadcast? Will you use mulch and, if so, what type?

A weed-free seed mix will be used, which will consist of Mountain Brome, Sandberg Bluegrass, Thickspike Wheatgrass, Pubescent Wheatgrass, Big Bluegrass, Big Sagebrush, Bitterbrush, Silverleaf Lupine, Blue Flax, and Louisiana Sagebrush with 20.15 pounds per acre broadcasted.

16. How are you providing temporary irrigation to the disturbed area?

Water trucks will provide temporary irrigation to the disturbed area.

17. Have you reviewed the revegetation plan with the Washoe Storey Conservation District? If yes, have you incorporated their suggestions?

No. Upon review, suggestions may be incorporated.

18. Are there any restrictive covenants, recorded conditions, or deed restrictions (CC&Rs) that may prohibit the requested grading?

Yes No If yes, please attach a copy.

Property Owner Affidavit

Applicant Name: _____

The receipt of this application at the time of submittal does not guarantee the application complies with all requirements of the Washoe County Development Code, the Washoe County Master Plan or the applicable area plan, the applicable regulatory zoning, or that the application is deemed complete and will be processed.

STATE OF NEVADA)
)
COUNTY OF WASHOE)

I, Bruce D Reeves
(please print name)

being duly sworn, depose and say that I am the owner* of the property or properties involved in this application as listed below and that the foregoing statements and answers herein contained and the information herewith submitted are in all respects complete, true, and correct to the best of my knowledge and belief. I understand that no assurance or guarantee can be given by members of Planning and Building.

(A separate Affidavit must be provided by each property owner named in the title report.)

Assessor Parcel Number(s): 046-080-03

Printed Name Bruce D Reeves

Signed Bruce D Reeves

Address 3451 Lisbon Ct.

Sparks, NV 89436

Subscribed and sworn to before me this
14 day of May, 2018.

[Signature]
Notary Public in and for said county and state

My commission expires: 02-17-2020



(Notary Stamp)

*Owner refers to the following: (Please mark appropriate box.)

- Owner
- Corporate Officer/Partner (Provide copy of record document indicating authority to sign.)
- Power of Attorney (Provide copy of Power of Attorney.)
- Owner Agent (Provide notarized letter from property owner giving legal authority to agent.)
- Property Agent (Provide copy of record document indicating authority to sign.)
- Letter from Government Agency with Stewardship

May 15, 2018 - 09:23 Doc Name: P:\Main\2018\0923\Drawings\Utility\Utility.dwg Updated By: Krossol

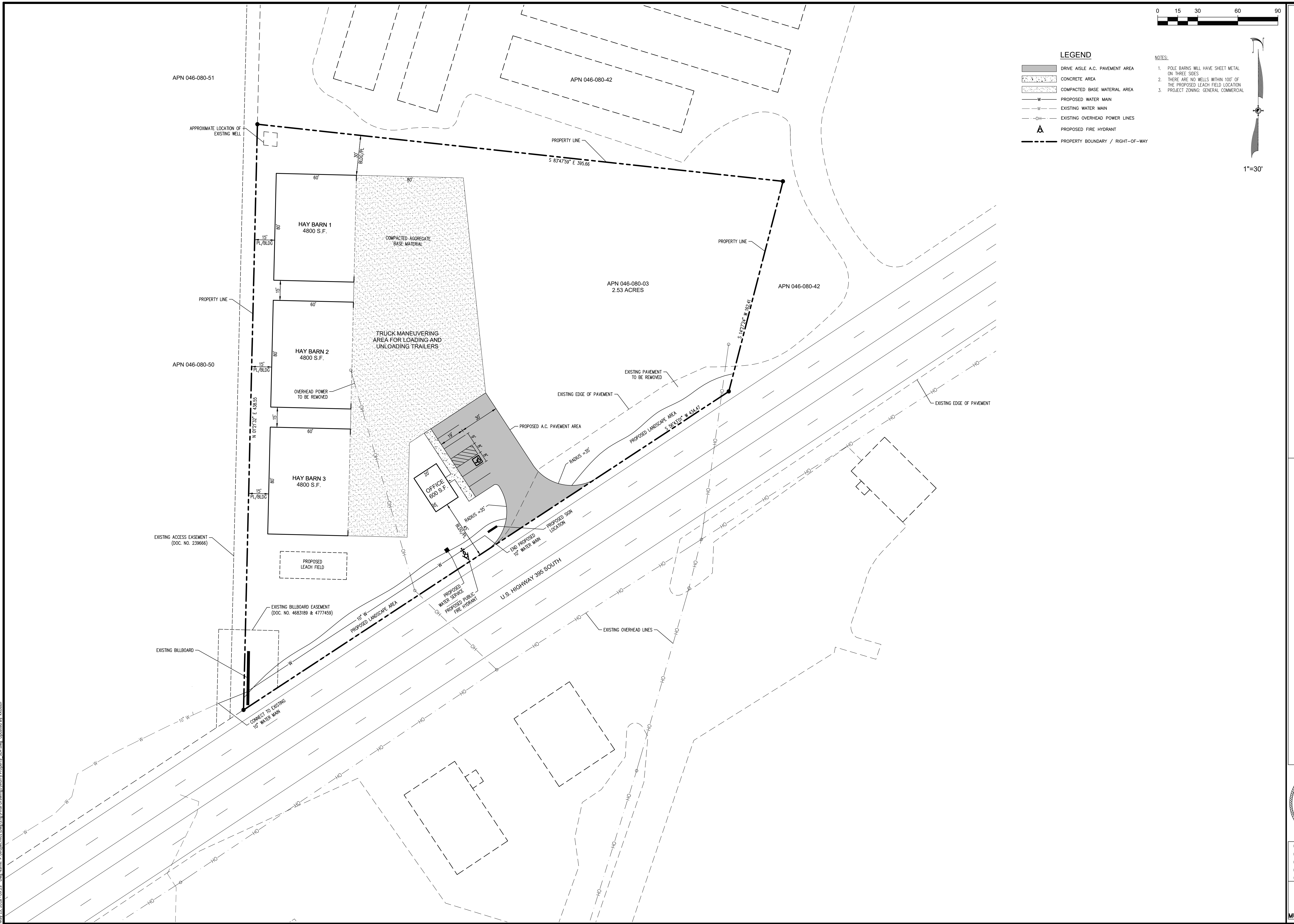

DRAWN BY	
CHECK BY	
DATE	
REVISIONS	

Manhard
CONSULTING LTD.

8850 Double R Boulevard, Suite 101, Reno, NV 89521 P: 775-748-3500 F: 775-748-3500 manhard.com
Civil Engineers • Surveyors • Water Resource Engineers • Water & Wastewater Engineers
Construction Managers • Environmental Scientists • Landscape Architects • Planners

**225 U.S. HIGHWAY 395 SOUTH
WASHOE VALLEY, NEVADA
PRELIMINARY SITE & UTILITY PLAN**

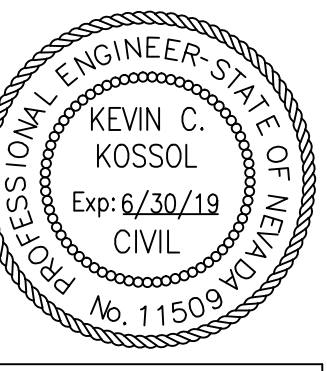

PROJ. MGR.:	CMB
PROJ. ASSOC.:	KCK
DRAWN BY:	SDF
DATE:	MAY 2018
SCALE:	1"=30'
SHEET	
C2 OF 3	
MUJWCNV01	

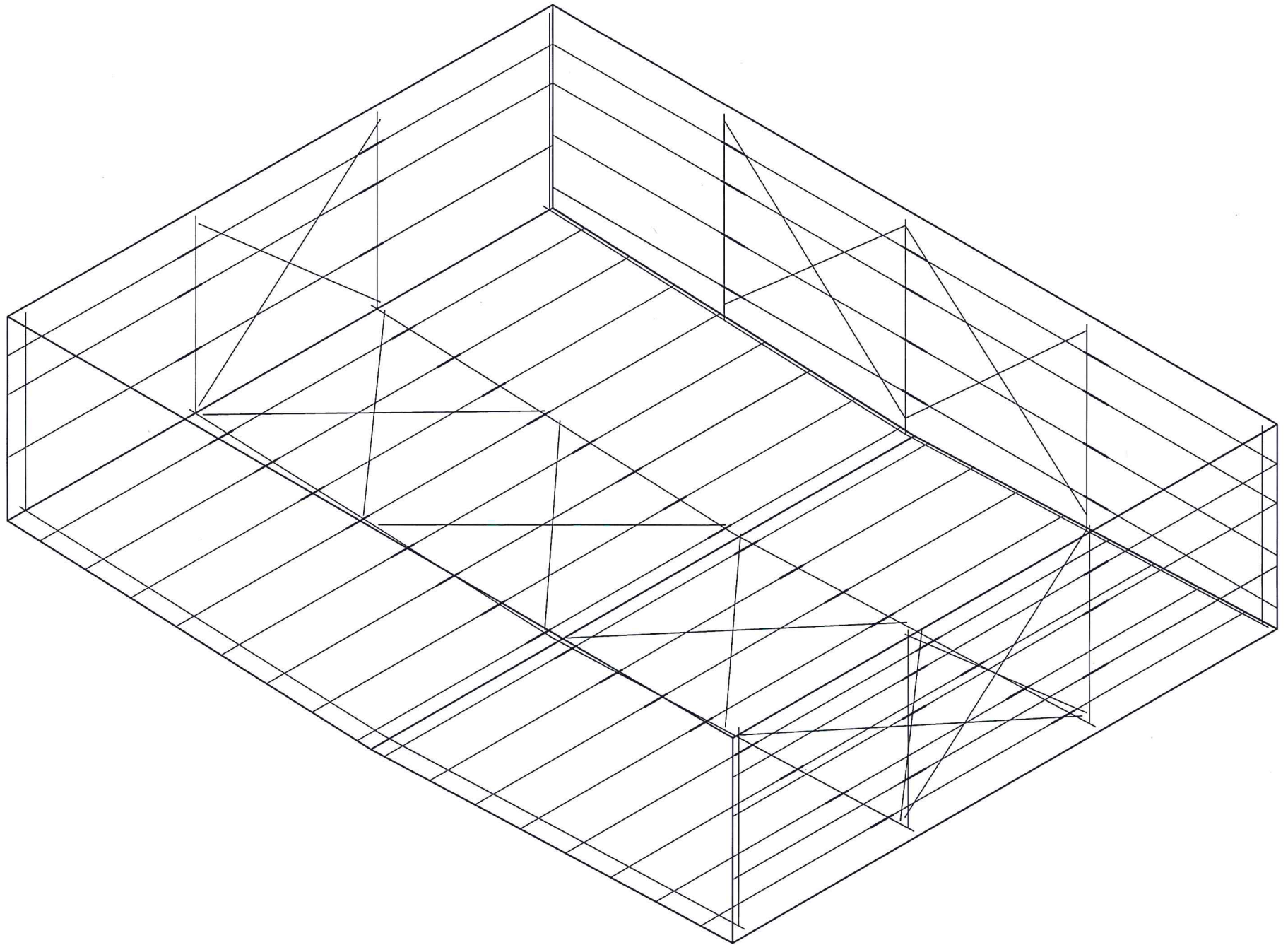

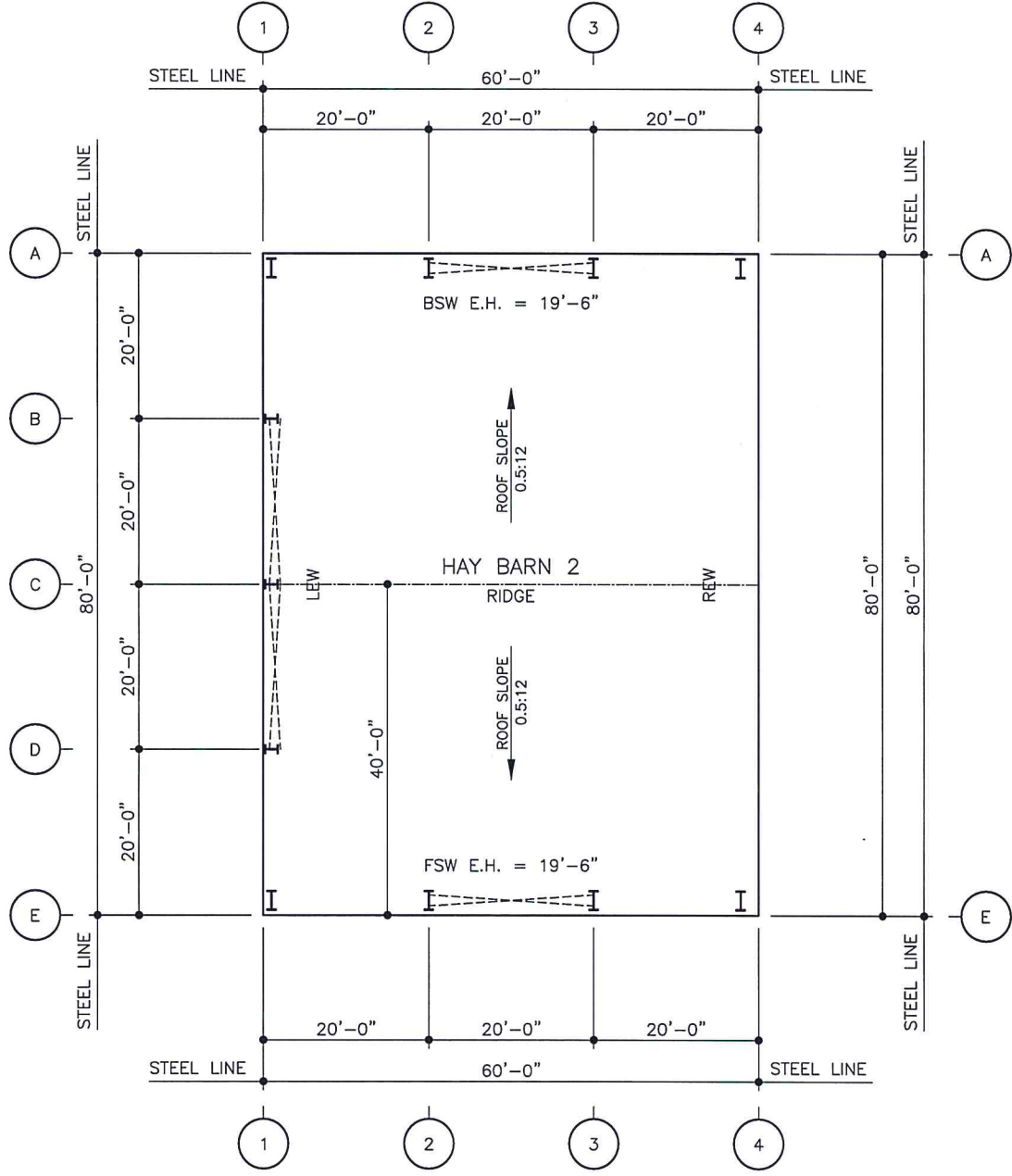

PROJECT NAME: MURRY PROPERTY- BARN 1 OP 2 B
 WASHOE VALLEY, NV
 CUSTOMER NAME: PINECREST CONSTRUCTION
 2 RENO, NV

DO NOT USE FOR FINAL CONSTRUCTION
 SHEET TITLE: PRELIMINARY FLOOR PLAN
 SHEET NUMBER: FP1
 QUOTE NUMBER: NOJ-18006-OPT 2

5/11/2018 2:18 PM

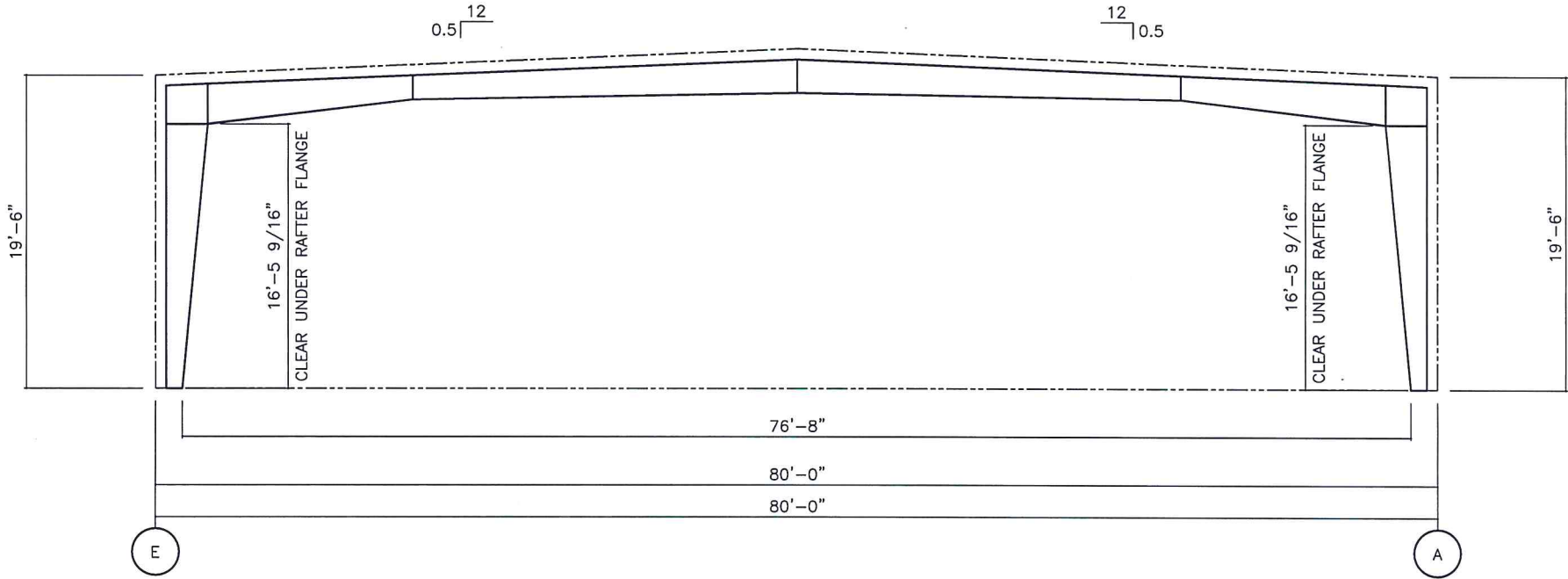

FRAME @ LINE(S) 2,3

*ALL CLEAR DIMENSIONS ARE SUBJECT TO CHANGE AT TIME OF FINAL DESIGN,
UNLESS NOTED OTHERWISE IN THE SPECIAL USER NOTES SECTION.



DO NOT USE FOR FINAL CONSTRUCTION		PROJECT NAME:	MURRY PROPERTY- BARN 1 OP 2 B
SHEET TITLE:		WASHOE VALLEY, NV	
PRELIMINARY FRAME CROSS SECTIONS		CUSTOMER NAME:	PINECREST CONSTRUCTION
SHEET NUMBER:	FX	QUOTE NUMBER:	NOJ-18006-OPT 2
			RENO, NV

KEY PLAN

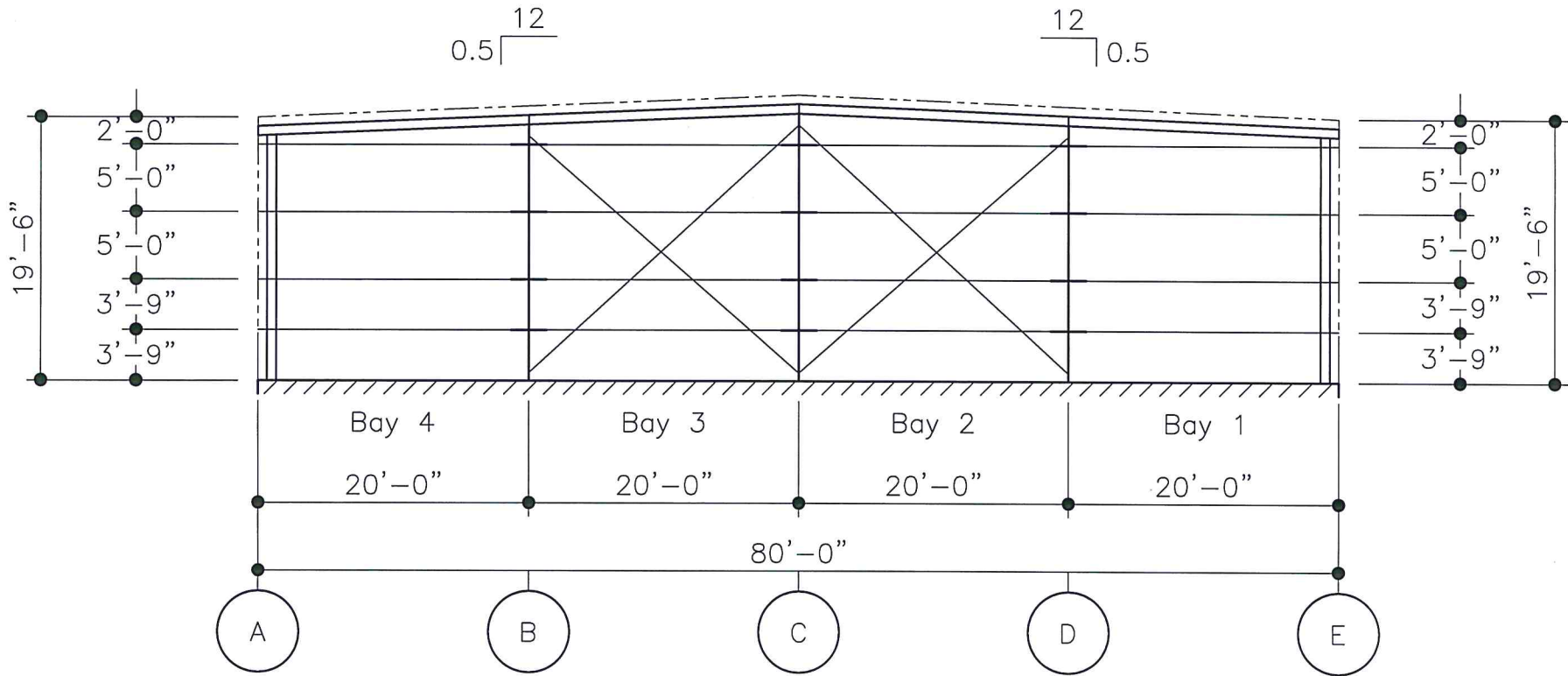

ELEVATION AT LINE 1



PROJECT NAME:
 MURRY PROPERTY- BARN 1 OP 2 B
 WASHOE VALLEY, NV
 CUSTOMER NAME:
 PINECREST CONSTRUCTION
 RENO, NV

DO NOT USE FOR FINAL CONSTRUCTION
 SHEET TITLE:
 PRELIMINARY STRUCTURAL ELEVATIONS
 SHEET NUMBER:
 ST5

5/11/2018 2:18 PM
 QUOTE NUMBER:
 NOJ-18006-OPT 4

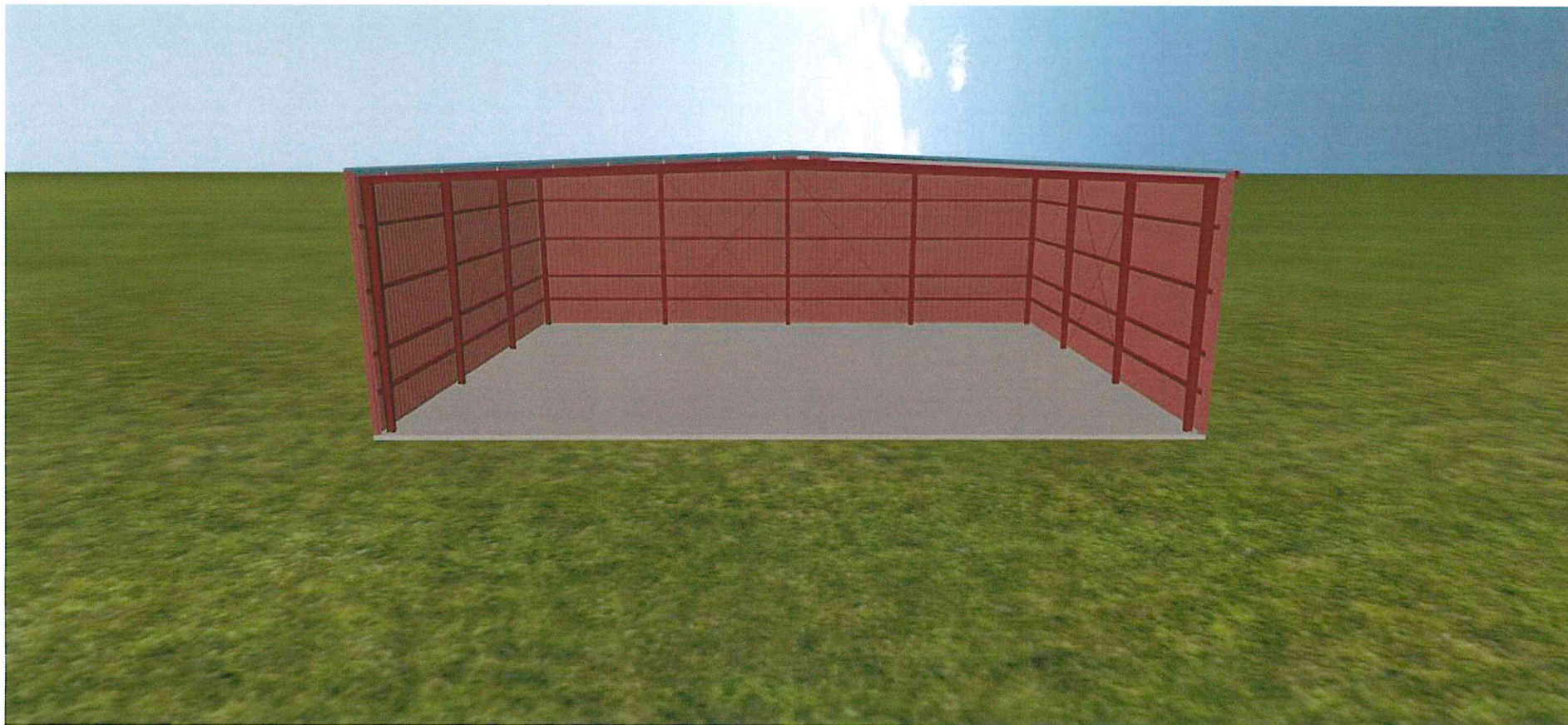

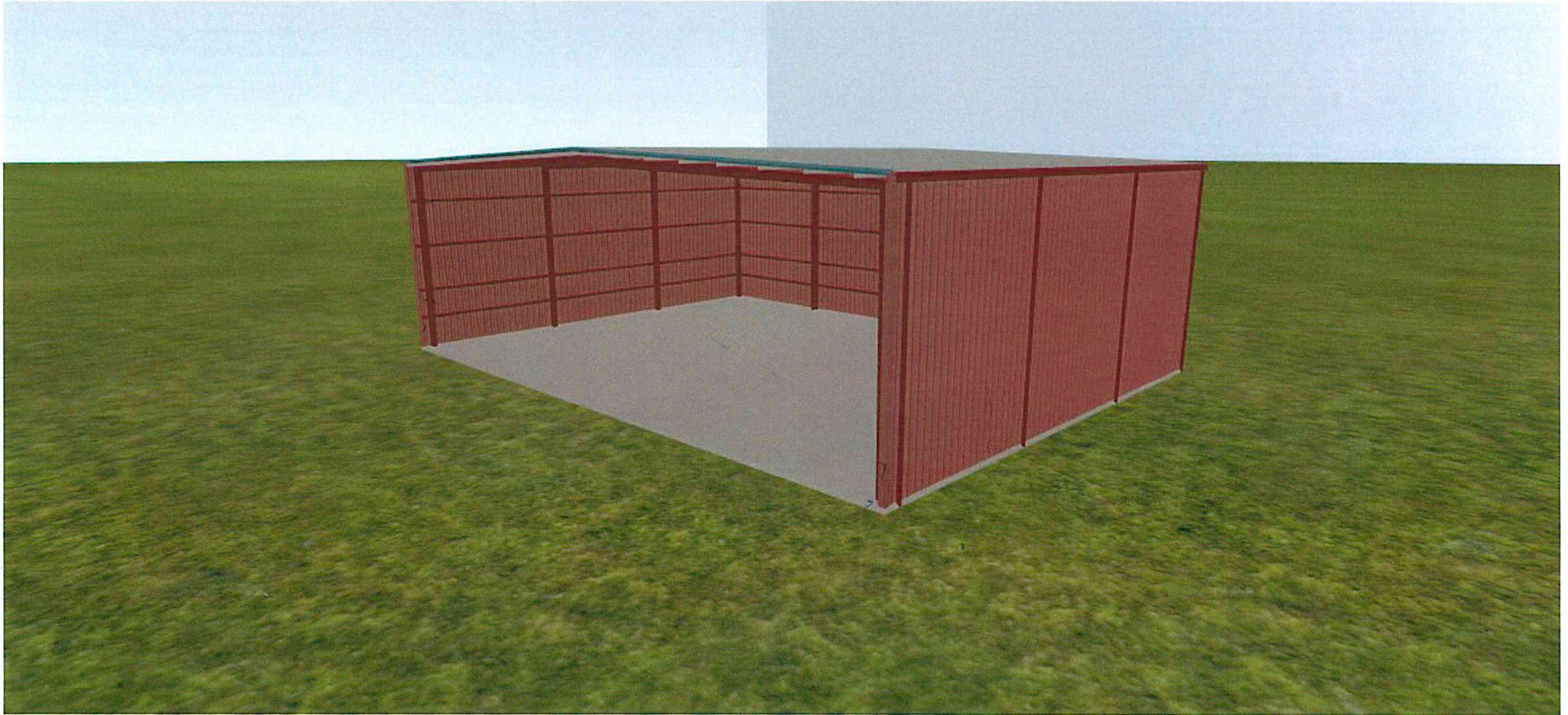

Community Services Department
Planning and Building
DIRECTOR'S MODIFICATION OF
PARKING/LANDSCAPING
(see page 5)
MINOR DEVIATION
(see page 7)
STANDARDS APPLICATION



Community Services Department
Planning and Building
1001 E. Ninth St., Bldg. A
Reno, NV 89520

Telephone: 775.328.6100

Washoe County Development Application

Your entire application is a public record. If you have a concern about releasing personal information, please contact Planning and Building staff at 775.328.6100.

Project Information		Staff Assigned Case No.: _____	
Project Name: 225 US Highway 395 S			
Project Description: Director's Modification of Parking/Landscaping Standards to allow for compacted aggregate base material in lieu of pavement for a loading and work area adjacent to the barns.			
Project Address: 225 US Highway 395 S, Washoe Valley, NV 89704			
Project Area (acres or square feet): 2.53 acres			
Project Location (with point of reference to major cross streets AND area locator): Located on US Highway 395 S, approximately .8 miles southwest of Eastlake Boulevard.			
Assessor's Parcel No.(s):	Parcel Acreage:	Assessor's Parcel No.(s):	Parcel Acreage:
046-080-03	2.53 acres		
Section(s)/Township/Range: Section 24 Township 17 Range 19			
Indicate any previous Washoe County approvals associated with this application: Case No.(s). N/A (submitted concurrently with a SUP for Grading Application)			
Applicant Information (attach additional sheets if necessary)			
Property Owner:		Professional Consultant:	
Name: Reeves Business Ventures		Name: Manhard Consulting	
Address: 3541 Lisbon Ct. Sparks, NV		Address: 241 Ridge St., Suite 400, Reno NV	
Zip: 89436		Zip: 89501	
Phone:	Fax:	Phone: 775-321-6538	Fax:
Email:		Email: kdowns@manhard.com	
Cell:	Other:	Cell: 775-313-3360	Other:
Contact Person:		Contact Person: Karen Downs	
Applicant/Developer:		Other Persons to be Contacted:	
Name: Murry Ranch, LLC		Name:	
Address: 21000 South Virginia Reno, NV		Address:	
Zip: 89521		Zip:	
Phone:	Fax:	Phone:	Fax:
Email: hayjay1955@gmail.com		Email:	
Cell:	Other:	Cell:	Other:
Contact Person: Jason Murry		Contact Person:	
For Office Use Only			
Date Received:	Initial:	Planning Area:	
County Commission District:		Master Plan Designation(s):	
CAB(s):		Regulatory Zoning(s):	

July 1, 2017

Director's Modification of Standards Parking/Landscape Application Supplemental Information

(All required information may be separately attached)

Chapter 110 of the Washoe County Code is commonly known as the Development Code Section 110.410.35 – Modification of Standards allows the Director of Planning and Building to modify parking standards due to the "unusual nature" of the establishment proposed. Section 110.412.05(d) – Review of Extenuating Circumstances allows the Director of Planning and Building to conduct a special review of landscaping standards resulting from "extenuating circumstances or physical conditions" on the proposed project site.

1. What modification to the parking standards are you requesting? **Be specific.** For example, if this is a parking space modification, how many parking spaces are required and how many are you proposing. If this request is to use decomposed gravel (DG), in lieu of asphalt, what is the proposed depth of and compacting of the DG? What portion of the parking area will be DG?

We are requesting a modification to allow for compacted aggregate base material in lieu of asphalt paving for a loading and work area adjacent to the proposed barns. The parking area will be paved with asphalt. The parking area and loading/work area is shown on the attached Site Plan. Development of the loading area will be based on recommendations in the Geotech Report which will be completed with Final Improvement Plans.

2. What modification to the landscaping standards are you requesting? **Be specific.** For example, is this a request to reduce the landscaping from 20% to 15%, or to utilize 50% inert materials at maturation?

N/A

3. Why is the modification necessary to the success of the project? **Be specific.** Please address the "unusual nature" of the establishment proposed or the "extenuating circumstances or physical conditions" on the proposed project site.

The modification will allow the agricultural operations to flow more smoothly by having a compacted aggregate base surface that is more conducive to agricultural equipment, and loading and unloading activities. Furthermore, if the area had asphalt surfacing, the maneuvering and operation of the agricultural equipment would cause cracks in the asphalt, and ultimately failure of the surface. The unusual nature of the agricultural equipment and loading and unloading activities causes the proposed modification in surface type to be necessary.

4. What exchanges are you proposing to mitigate the effect of the reduction in landscaping, parking, or both? (For example: planting a specific number of additional trees in exchange for a reduction in required landscape coverage.)

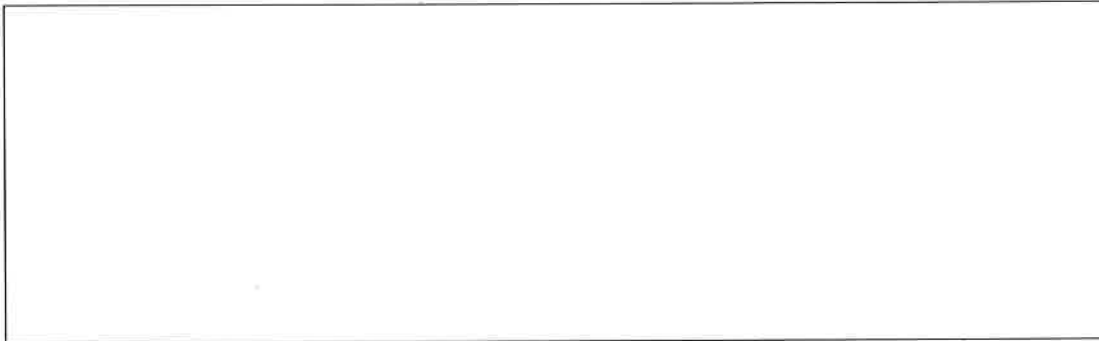

Property Owner Affidavit

Applicant Name: _____

The receipt of this application at the time of submittal does not guarantee the application complies with all requirements of the Washoe County Development Code, the Washoe County Master Plan or the applicable area plan, the applicable regulatory zoning, or that the application is deemed complete and will be processed.

STATE OF NEVADA)
)
COUNTY OF WASHOE)

I, Bruce D Reeves
(please print name)

being duly sworn, depose and say that I am the owner* of the property or properties involved in this application as listed below and that the foregoing statements and answers herein contained and the information herewith submitted are in all respects complete, true, and correct to the best of my knowledge and belief. I understand that no assurance or guarantee can be given by members of Planning and Building.

(A separate Affidavit must be provided by each property owner named in the title report.)

Assessor Parcel Number(s): 046-080-03

Printed Name Bruce D Reeves

Signed Bruce D Reeves

Address 3451 Lisbon Ct.

Sparks, NV 89436

Subscribed and sworn to before me this
14 day of May, 2018.

Milena Tonino
Notary Public in and for said county and state

My commission expires: 02-17-2020

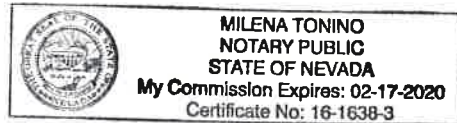

(Notary Stamp)

*Owner refers to the following: (Please mark appropriate box.)

- Owner
- Corporate Officer/Partner (Provide copy of record document indicating authority to sign.)
- Power of Attorney (Provide copy of Power of Attorney.)
- Owner Agent (Provide notarized letter from property owner giving legal authority to agent.)
- Property Agent (Provide copy of record document indicating authority to sign.)
- Letter from Government Agency with Stewardship

Washoe County Treasurer
Tammi Davis

Washoe County Treasurer
P.O. Box 30039, Reno, NV 89520-3039
ph: (775) 328-2510 fax: (775) 328-2500
Email: tax@washoecounty.us

Bill Detail

[Back to Account Detail](#)
[Change of Address](#)
[Print this Page](#)

Washoe County Parcel Information

Parcel ID	Status	Last Update
04608003	Active	5/14/2018 2:06:27 AM
Current Owner: REEVES BUSINESS VENTURES 3451 LISBON CT SPARKS, NV 89436		SITUS: 225 US HIGHWAY 395 S WASHOE COUNTY NV
Taxing District 4000		Geo CD:
Legal Description		
Township 17 Section 24 Lot Block Range 19 SubdivisionName _UNSPECIFIED		

Installments

Period	Due Date	Tax Year	Tax	Penalty/Fee	Interest	Total Due
INST 1	8/21/2017	2017	\$0.00	\$0.00	\$0.00	\$0.00
INST 2	10/2/2017	2017	\$0.00	\$0.00	\$0.00	\$0.00
INST 3	1/1/2018	2017	\$0.00	\$0.00	\$0.00	\$0.00
INST 4	3/5/2018	2017	\$0.00	\$0.00	\$0.00	\$0.00
Total Due:			\$0.00	\$0.00	\$0.00	\$0.00

Tax Detail

	Gross Tax	Credit	Net Tax
State of Nevada	\$57.42	(\$4.27)	\$53.15
Truckee Meadows Fire Dist	\$182.39	(\$13.55)	\$168.84
Washoe County	\$470.06	(\$34.91)	\$435.15
Washoe County Sc	\$384.53	(\$28.57)	\$355.96
WASHOE VALLEY WATER BASIN	\$7.30	\$0.00	\$7.30
Total Tax	\$1,101.70	(\$81.30)	\$1,020.40

Payment History

Tax Year	Bill Number	Receipt Number	Amount Paid	Last Paid
2017	2017071418	U17.633	\$1,020.40	7/18/2017

Pay By Check

Please make checks payable to:
**WASHOE COUNTY
TREASURER**

Mailing Address:
P.O. Box 30039
Reno, NV 89520-3039

Overnight Address:
1001 E. Ninth St., Ste
D140
Reno, NV 89512-2845

Change of Address

All requests for a mailing address change must be submitted in writing, including a signature (unless using the online form).

To submit your address change online [click here](#)

Address change requests may also be faxed to:
(775) 328-2500

Address change requests may also be mailed to:
Washoe County Treasurer
P O Box 30039
Reno, NV 89520-3039

The Washoe County Treasurer's Office makes every effort to produce and publish the most current and accurate information possible. No warranties, expressed or implied, are provided for the data herein, its use, or its interpretation. If you have any questions, please contact us at (775) 328-2510 or tax@washoecounty.us

This site is best viewed using Google Chrome, Internet Explorer 11, Mozilla Firefox or Safari.